



**WE GIVE FORM AND LIGHT  
TO YOUR IDEAS**

[www.marnigroup.com](http://www.marnigroup.com)



CONTENTS

**DIGITAL PRINTING** P/9

- FROM DRAFTING TO RENDERING
- TECHNOLOGY
- PRINT MEDIA

**SIGNS** P/15

- PRODUCTS
- LUMINA
- PROFILIA

**INSTALLATIONS SET-UPS** P/21

“WORK HARD AND...

SUCCESS WILL FOLLOW YOU”



## Like all of us, we are children of our history.

A history, however, which deserves, perhaps more than others, to be told and listened to in order to truly understand the spirit that drives us and which continues to drive us to this day.

**A bet that began many years ago from nothing to give shape and light to our dreams.**

**A challenge won thanks to constant commitment, hard work and the strong desire to be able to recognise ourselves in what we do because we know how best to achieve our goals.**

Challenges do not scare us, instead they stimulate and inspire us to take new paths and to find new solutions to successfully experiment with new horizons.



**8.000**

Square meters  
Gussago / Production

**120**

Employees and  
collaborators

**+30**

company  
machines

**+2.000**

work sites  
/ year

**100.000**

meters  
LED / year

## Responsible from start to finish and beyond

We follow you in every phase of the project.  
Every choice as well as every decision is well-balanced.



We are and will be, for each phase of the project, the only interlocutor you will deal with.



From inspections to feasibility checks, from the exact quotation of the intervention to the creation of the layouts, from the monitoring of each work phase to the warranty with the release of the necessary certifications.



We also take care of the request for the necessary permits and authorisations for you, in consultation with all the relevant bodies.



Our assistance does not end with the delivery of the project but also continues in the after-sales period.



## Fast, precise, flexible and punctual

Over the years, your success and your satisfaction have not only been a source of great satisfaction for us, but the true ingredient that has led us to become one of the leading companies in the sector at national level.





## M FOR METHOD

# 1 Identifying the goals

An open and in-depth collaboration, with respect to the results you aim to achieve, your expectations and desires, will allow us not only to work in harmony but to develop an analysis that will lead to a winning strategy.

**Identifying the objectives and adopting an efficient model is the core of a successful creative process.**

# 2 Analysis and strategy

From analysis to strategy to find the best solution for you thanks to experience, expertise, passion and precision.

Our designers and planners will guide you so that your 11 brand is communicated in the best way possible.

We carefully follow every phase of the development of a project so that, starting from the idea, we arrive at an original and successful installation.

# 3 Solutions

We are able to manage any type of project in any place, identifying the solution that best suits your needs.

**We provide you with a very high degree of customisation: we can create any shape in any material.**

Each market is different as well as the reactions with respect to the methods of communication. We are able to transform each project in an attractive and effective work.



## DIGITAL PRINTING

We are able  
to print on any  
medium of any  
size.

Quality is always guaranteed.

Printing is a constantly evolving world and, as such, it is necessary to always be up to date and to use the latest technologies to guarantee an excellent result.

We have state-of-the-art machinery as a greater guarantee of a product that will increase the value of your communication.





## Quality, speed and innovation

Thanks to our technologically advanced printing machines, we are able to create high quality images on a variety of media. Advertising materials, hoardings, canvas prints, backlit advertising media, banners and all the more complex graphics, suitable for communication, can be created.

All the inks are water and light resistant as standard for high quality, long-lasting large format prints. Another fundamental aspect is the printing speed: professional results, even for high runs, in the shortest possible time.

14

## DESIGN

**An impeccable result starts from the design.**

Our design department is made up of a team with considerable experience, which makes use of the most modern IT design tools.

## RENDERING

**We present the final product even before making it.**

We offer a highly professional service that is able to create graphic and architectural proposals through rendering that allow displaying of the final result in the required setting.

## PROTOTYPE AND CREATION

Our specialist technicians are able to complete even the most complex orders and to find the best solutions quickly.



## TECHNOLOGY

**A constantly updated and high performing machine fleet.**

Latest-generation and always up-to-date printing machines and cutting machines. The constant maintenance of our machinery allows us to be always ready to satisfy every customer requirement.

15





## PRINT MEDIA

The use of innovative materials, all certified for their intended use, allows the renewal of furnishings, walls, ceilings, glass, floors, façades, lifts and small spaces, creating real spaces for communication with the customer and with the users in general.



### Adhesive films of the best brands

Four-colour process prints, hot laminated with short- and long-lasting transparent protective adhesive film.

#### Translucent films

For the decoration of luminous signs.

#### Colour adhesive films

For “pre-spaced lettering” use.

#### Sandblasted or sanded adhesive films

For stained glass decoration.

#### One way

With its wide applications in the field of decoration of shop windows, stands, vehicles and many other creative solutions.

#### Semi-rigid repositionable sticker

For the decoration of luminous signs.  
To reduce interventions by specialist personnel.

#### RECOMMENDED USES

Signage, vehicle decoration, shop window decoration, smooth or corrugated indoor and outdoor surfaces. Opaque films for wall or floor decorations, short-lasting adhesive for events or trade fair stand set-ups.

### Sheets and fabrics

Four-colour prints.

#### Single-sided PVC sheet

Full colour prints.

#### Mesh sheet

Single-sided PVC mesh, four-colour print

#### Night & day one-sided PVC sheet

With black core on the back to block the passage of light.

#### Two-sided block out PVC sheet

Single-sided PVC mesh, four-colour print.

#### Flag fabric

Ideal for flags, banners and curtains.

#### Back light and pearl PVC sheet

Backlit for luminous signs.

#### Sheets in polyester and canvas fabric

For promotional material, shop windows, medium-large surface banners.

#### RECOMMENDED USES

Flags, banners, curtains, shop windows, creation of banners of medium-large surfaces, indoor and outdoor.

## Rigid panels

Direct four-colour printing.

### Expanded PVC

Forex type, 3; 5; 8; 10; 19 mm to create panels, signage, interior design, exhibitions, trade fairs.

### Translucent films

For the decoration of luminous signs.

### Kapa line

“Sandwich”, th. 5 in expanded extruded polystyrene and two sheets of cardboard. Ideal for promotional material.

### Piuma

Compact extruded polystyrene and 1 mm semi-expanded PVC sheets. Ideal for medium- and long-term promotional material

### Polionda

It is a product with a honeycomb structure made of polypropylene that stands out for its low cost and resistance capacity outdoors. Available thicknesses: 3.5-5-10 mm.

### Aluminium composite

(Dibond, Alucobond, etc.). Composite sheet consisting of a “Sandwich” of two sheets of aluminium and polyethylene printed directly in four-colour process, light, robust, stable, ideal for indoor and outdoor communication.

### Methacrylate (Plexiglass)

Transparent, opal, white or coloured for illuminated plaques and signs and interior furnishings.

### RECOMMENDED USES

Panels, signage, interior and exterior set-up, exhibitions, trade fairs, promotional material, luminous plaques and signs and furnishings.

## Cardboard

It is a cardboard panel consisting of an internal honeycomb core. Ultra light and versatile, it offers surfaces that are well suited to printing and/or scoring. It also represents a “green” choice in the field of advertising, panels and customised displays.

Available thicknesses: 10-16-20 mm

Available colours: white - black - Havana.

## Magnetic

It is a versatile material that is highly suited to temporary decorations on vehicles or metal surfaces. Easily shaped, it is also appropriate for the signage or temporary communication function. It can be used both indoors and outdoors and faithfully reproduces the desired print.





## SIGNS PRODUCTS

### Custom creativity

There are no universal solutions but only individual ones, designed and created to give greater effectiveness to the visual message. Our signs are characterised by the solidity and lightness of the structures and versatility of use, both indoors and outdoors.

Signs with attention to every detail and fully customisable. Innovative single-sided and double-sided solutions are available in the luminous and non-luminous versions. All signs are designed in-house with craftsmanship and the highest quality materials.





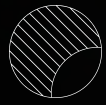

Direct light



## LAEFFE

Boxed sign with  
luminous front and perimeter edge

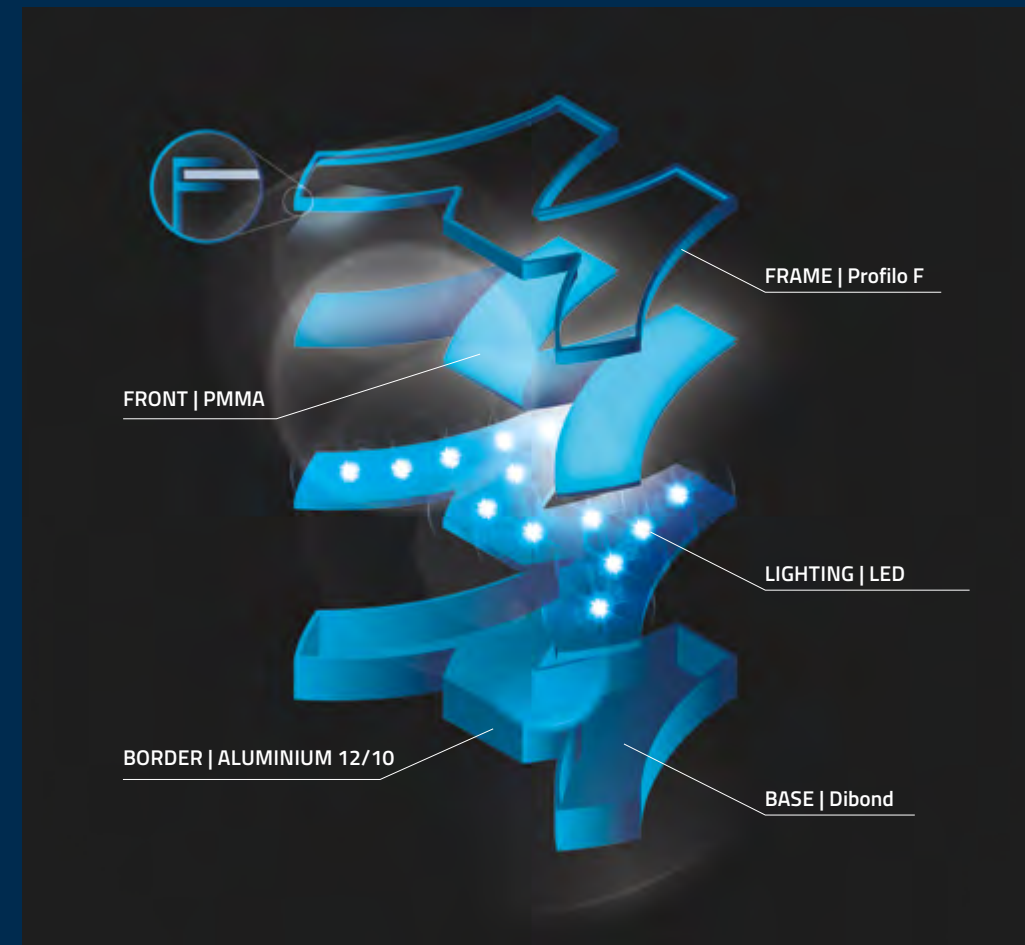

23

Usage: indoor and outdoor  
Size: medium / large  
Certification: CE



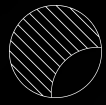

Direct light



## CLASSIC

Boxed sign with  
with fully luminous front

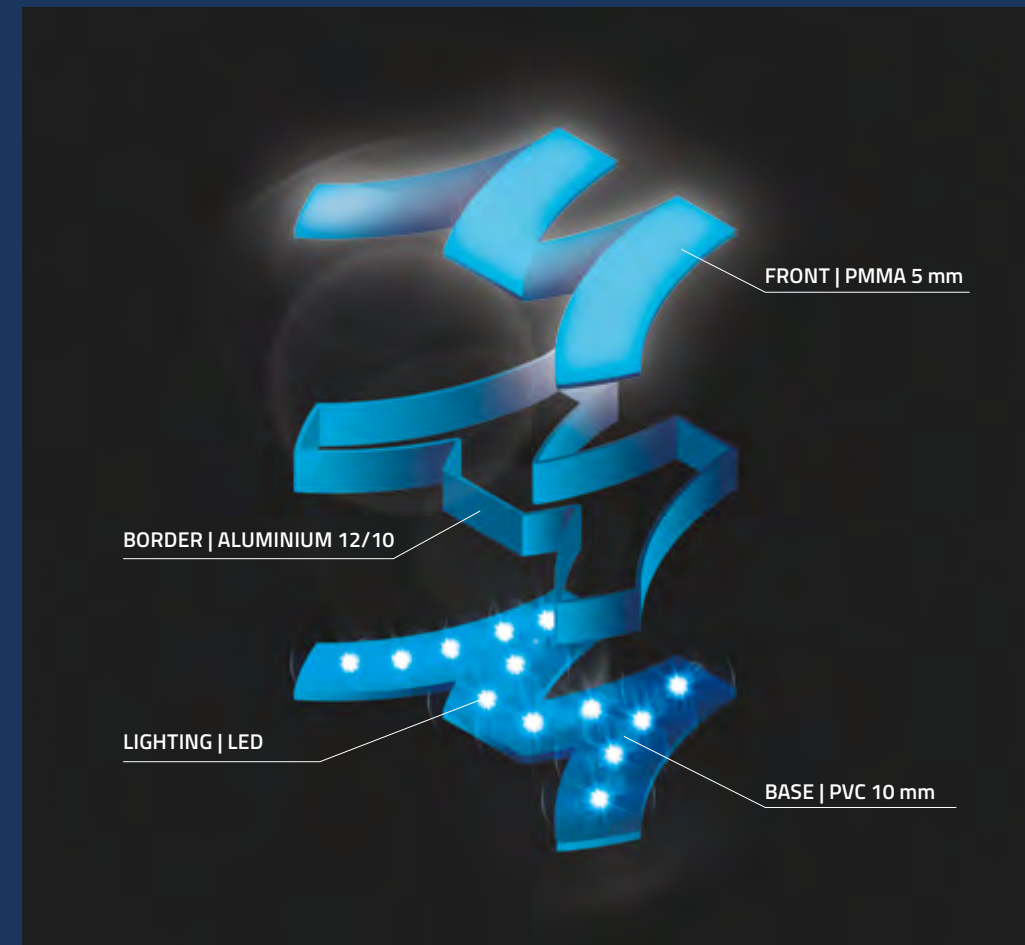

Usage: indoor and outdoor  
Size: medium / large  
Certification: CE



Direct light



## SOLID - F

Boxed sign with fully luminous embossed front

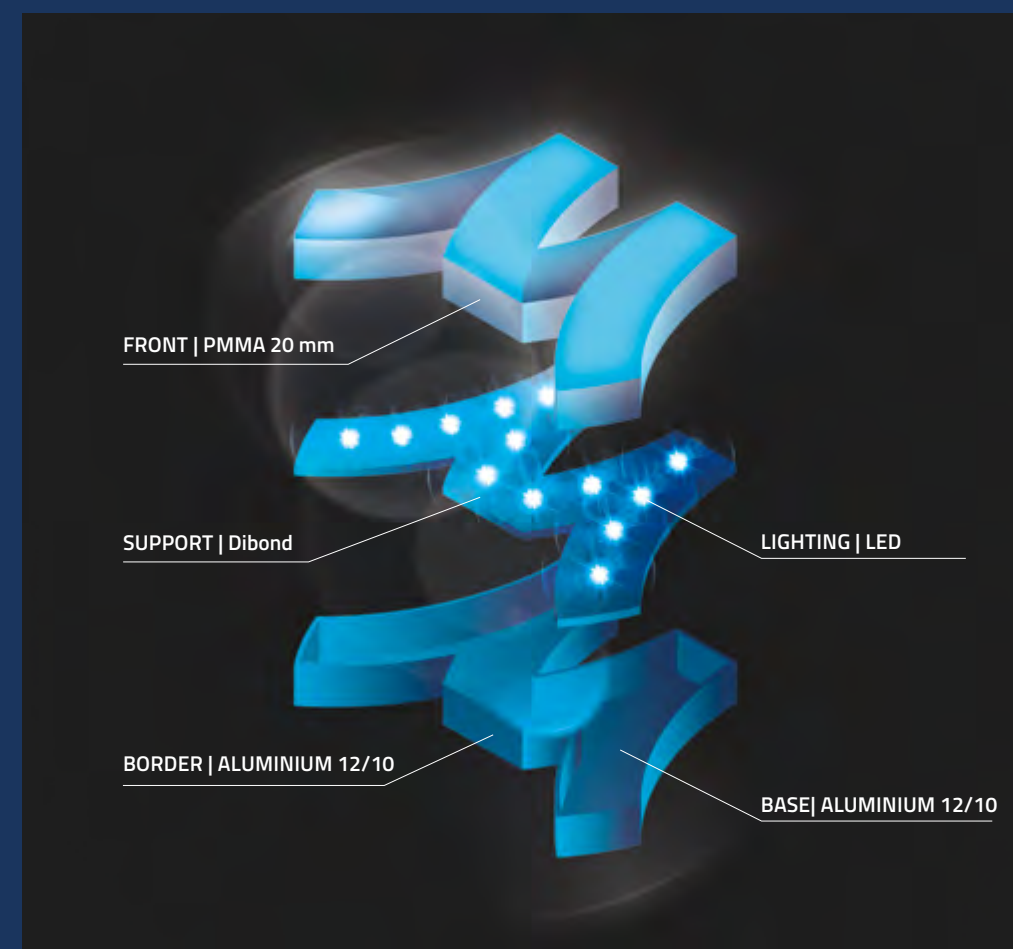

Usage: indoor and outdoor  
Size: medium / large  
Certification: CE





Direct light



## FLEX NEON

Boxed sign with illuminated open front with flex neon



Usage: indoor and outdoor  
Size: medium / large  
Certification: CE



Direct light



## PLEXI

Boxed sign with fully luminous side edge and front

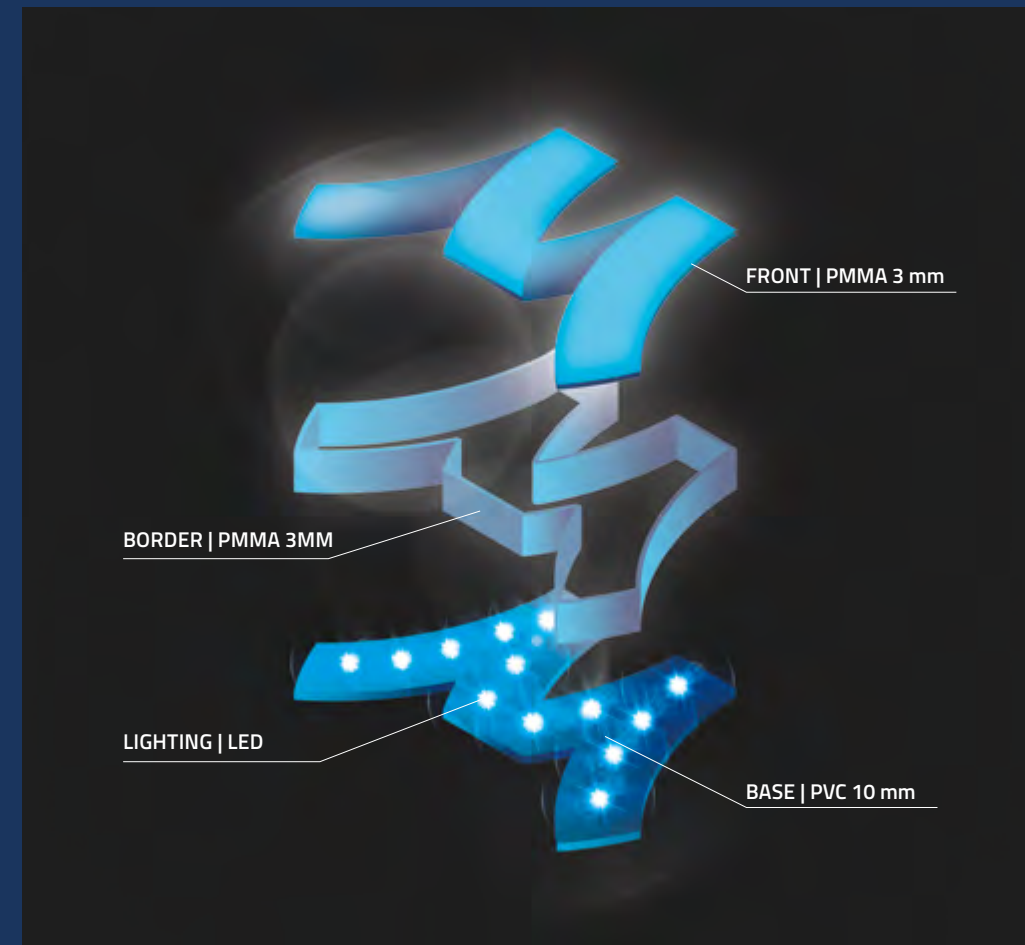

Usage: indoor and outdoor  
Size: small / medium / large  
Certification: CE



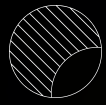

Direct light

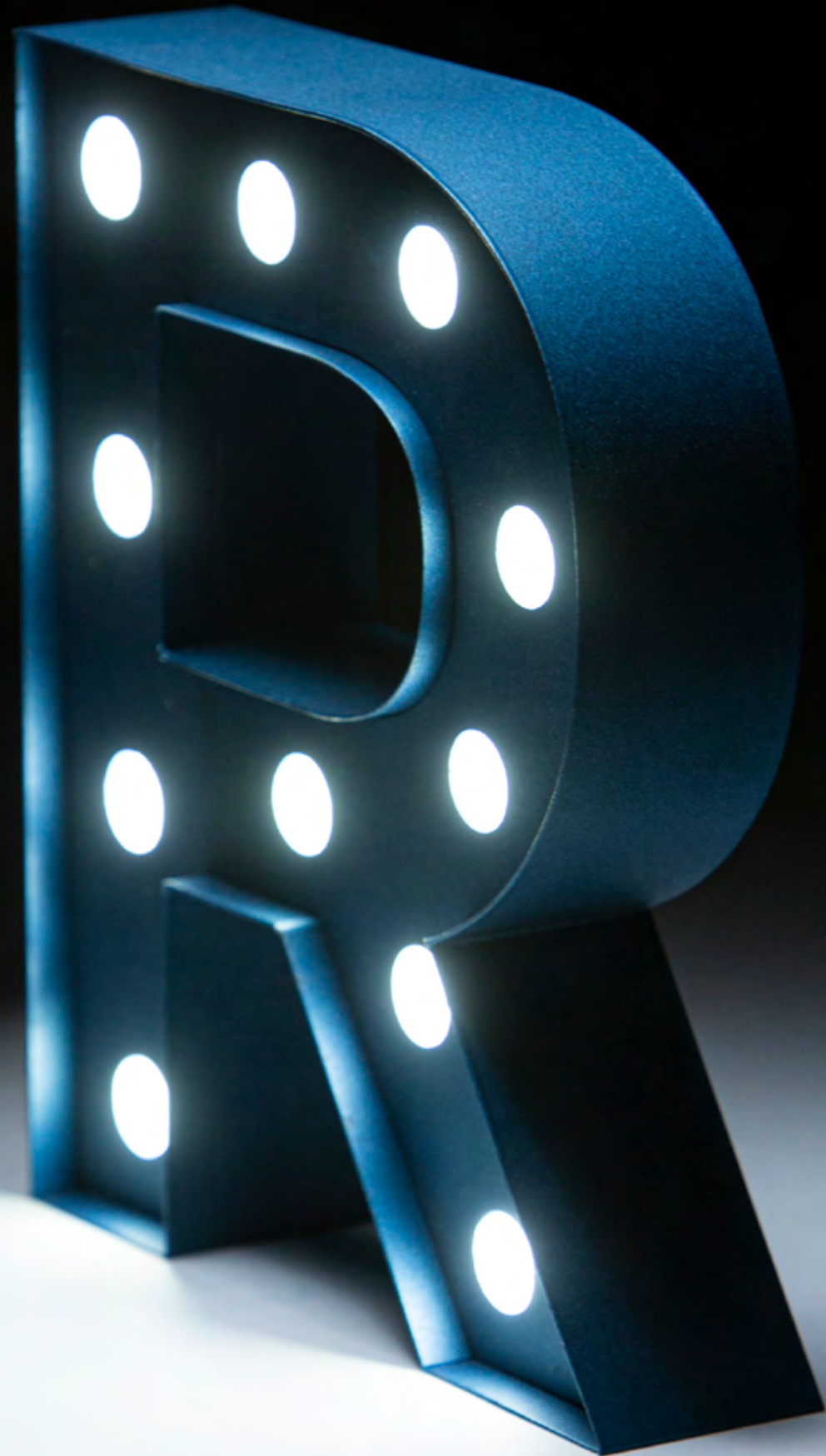

## BULB

Boxed sign with luminous bulbs

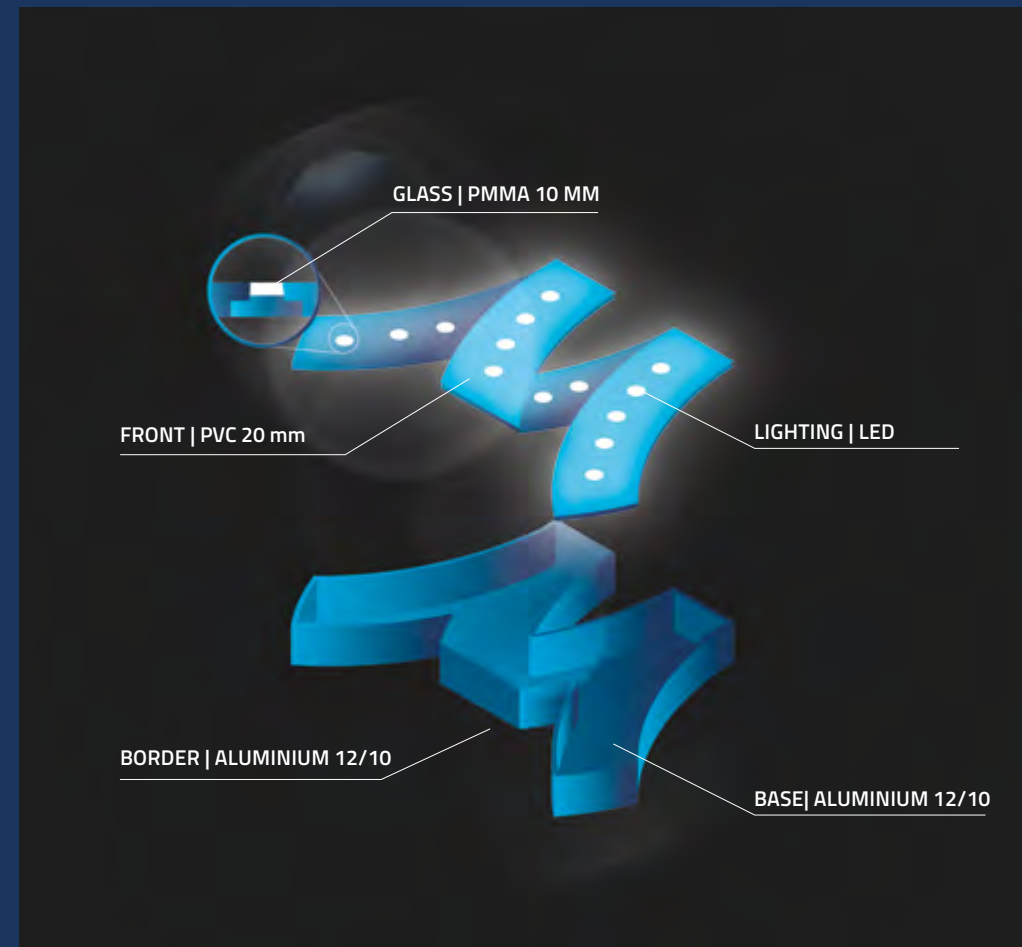

Usage: indoor and outdoor  
Size: small / medium  
Certification: CE



Direct light



## DOUBLE-SIDED

Boxed sign with fully luminous front and back

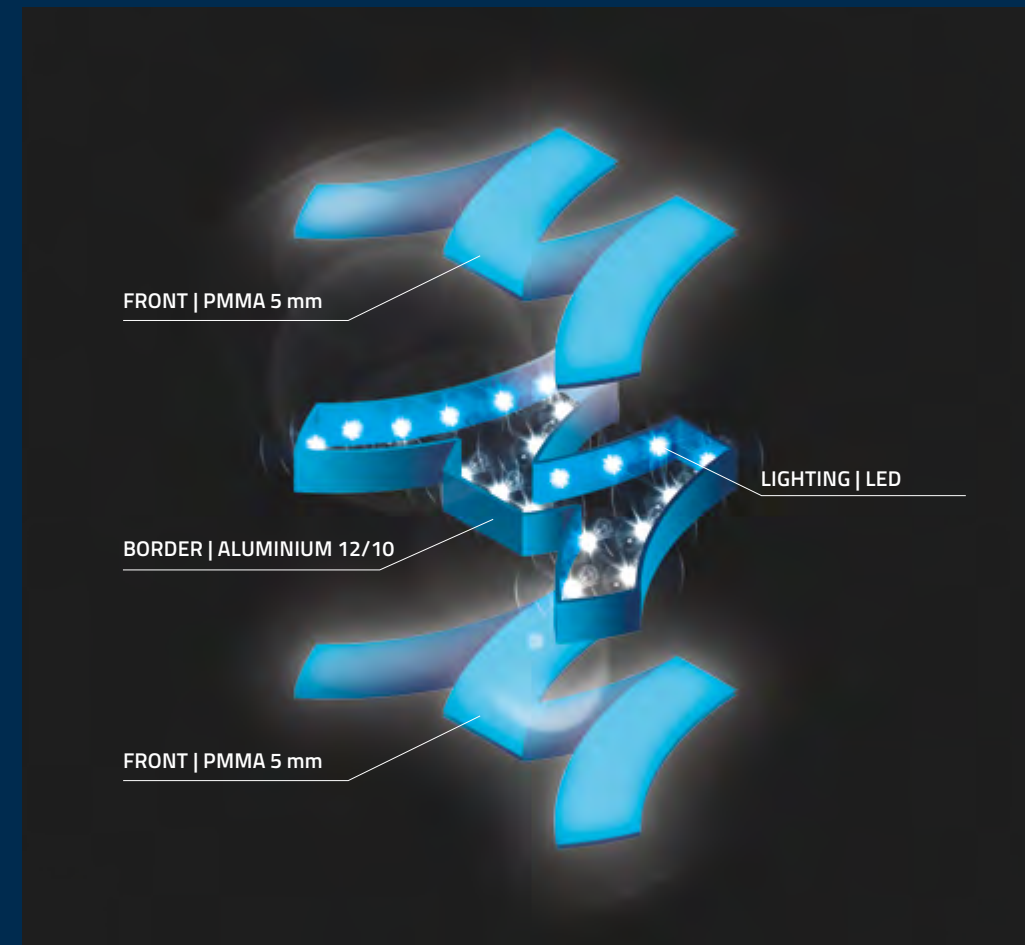

35

Usage: indoor and outdoor  
Size: small / medium  
Certification: CE





Reflected light



## BACKLITE

Boxed sign with  
luminous base with reflected light and  
spacers

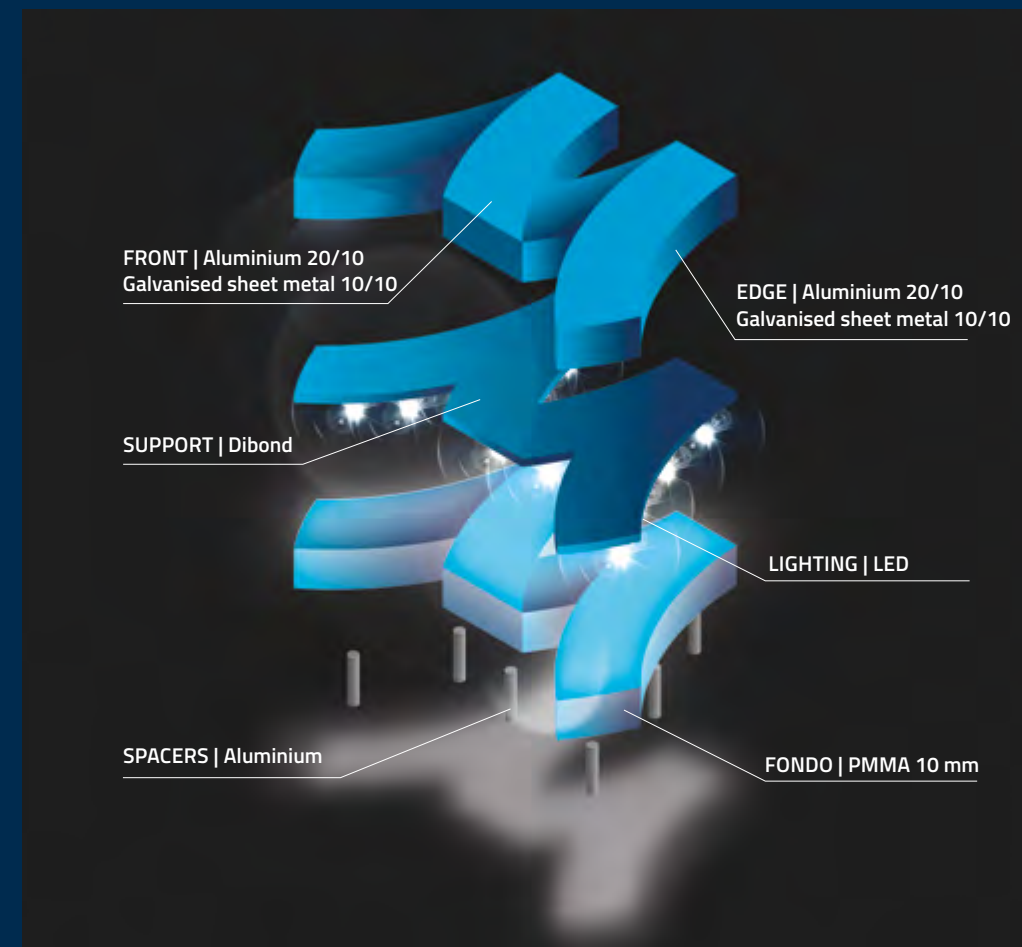

Usage: indoor and outdoor  
Size: small / medium / large  
Certification: CE



Reflected light



## BACKLITE - SOLID

Boxed sign with  
fully luminous embossed base

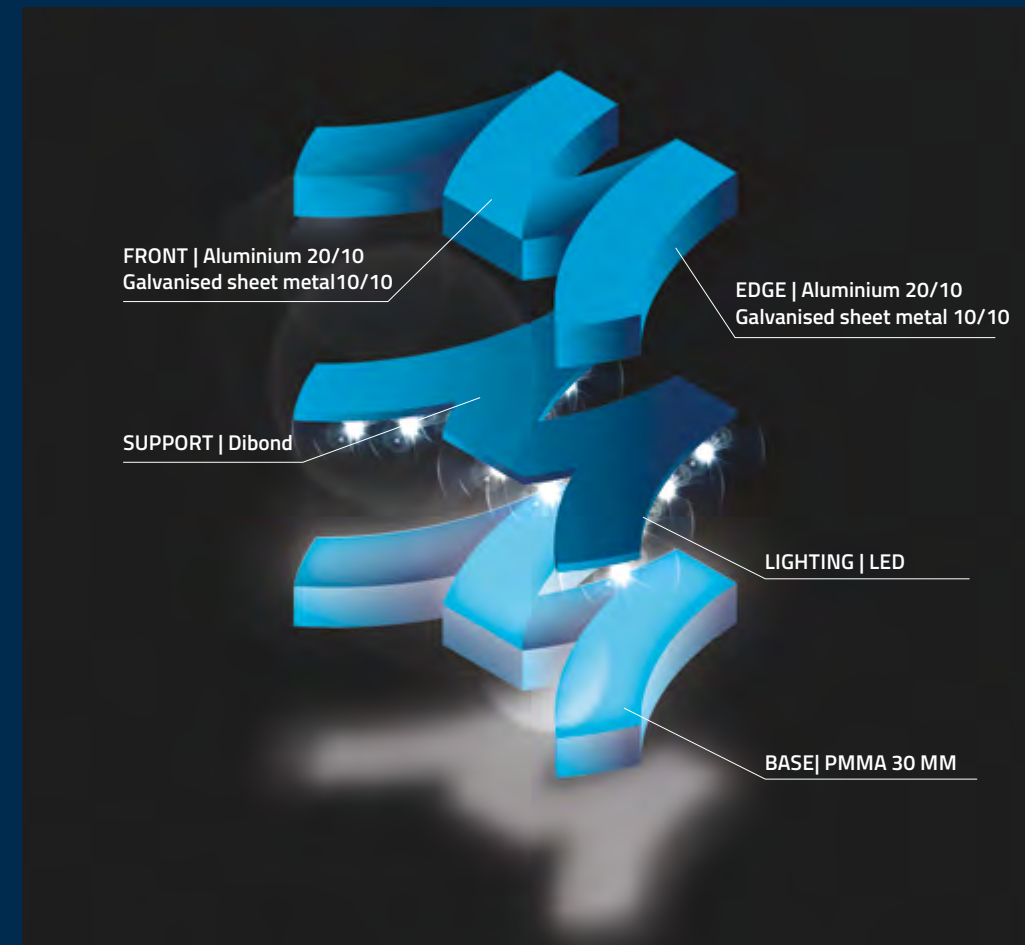

39

Usage: indoor and outdoor  
Size: small / medium  
Certification: CE





## ROMA MONO

Single-sided box with luminous front and perimeter frame

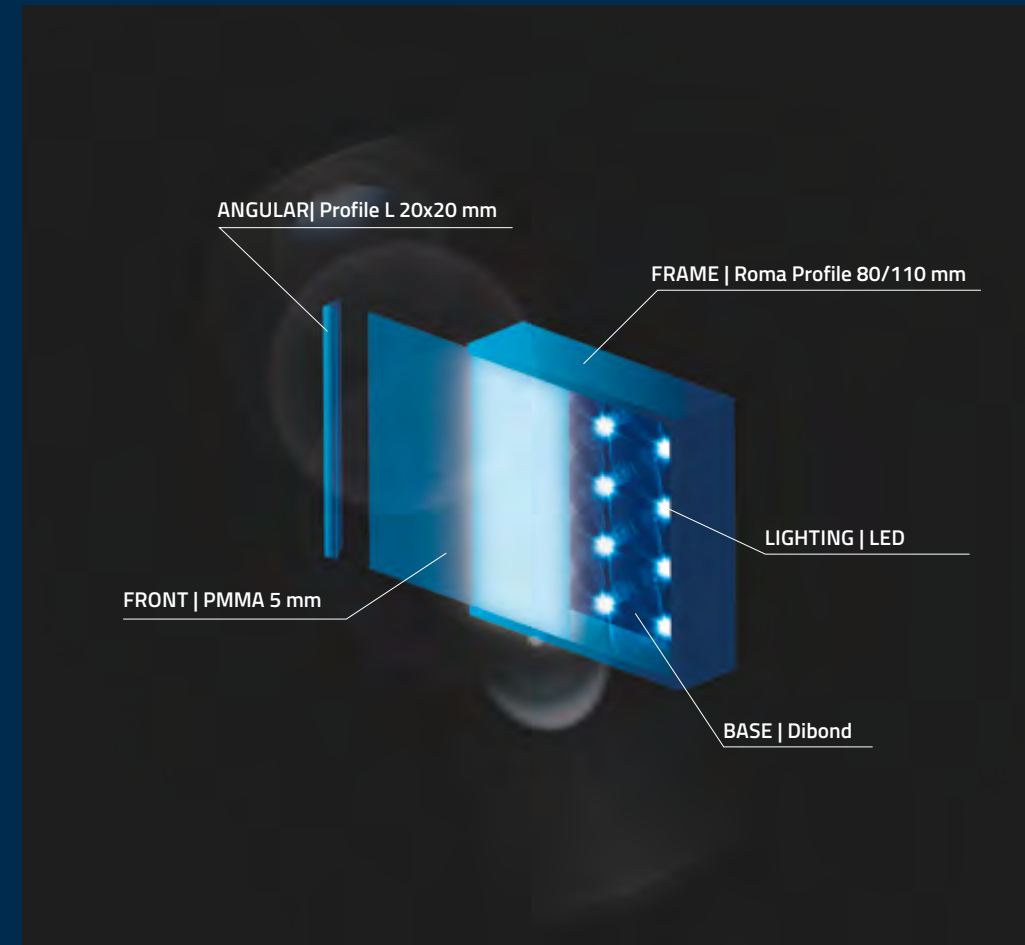

Usage: indoor and outdoor  
Size: small / medium  
Certification: CE



## DOUBLE-SIDED ROMA

Double-sided box with  
luminous front/back and perimeter frame

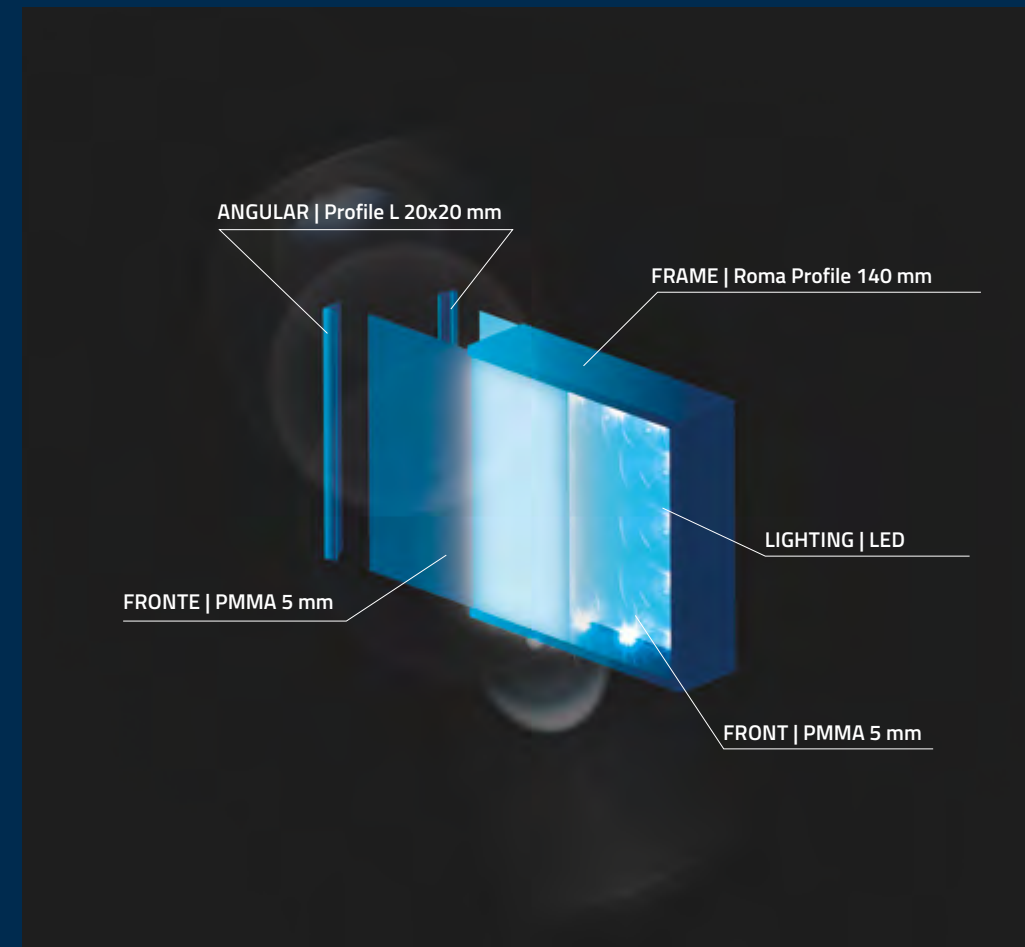

Usage: indoor and outdoor  
Size: small / medium / large  
Certification: CE





## PERFORATED

Single/double-sided perforated box with lighting of the perforated parts

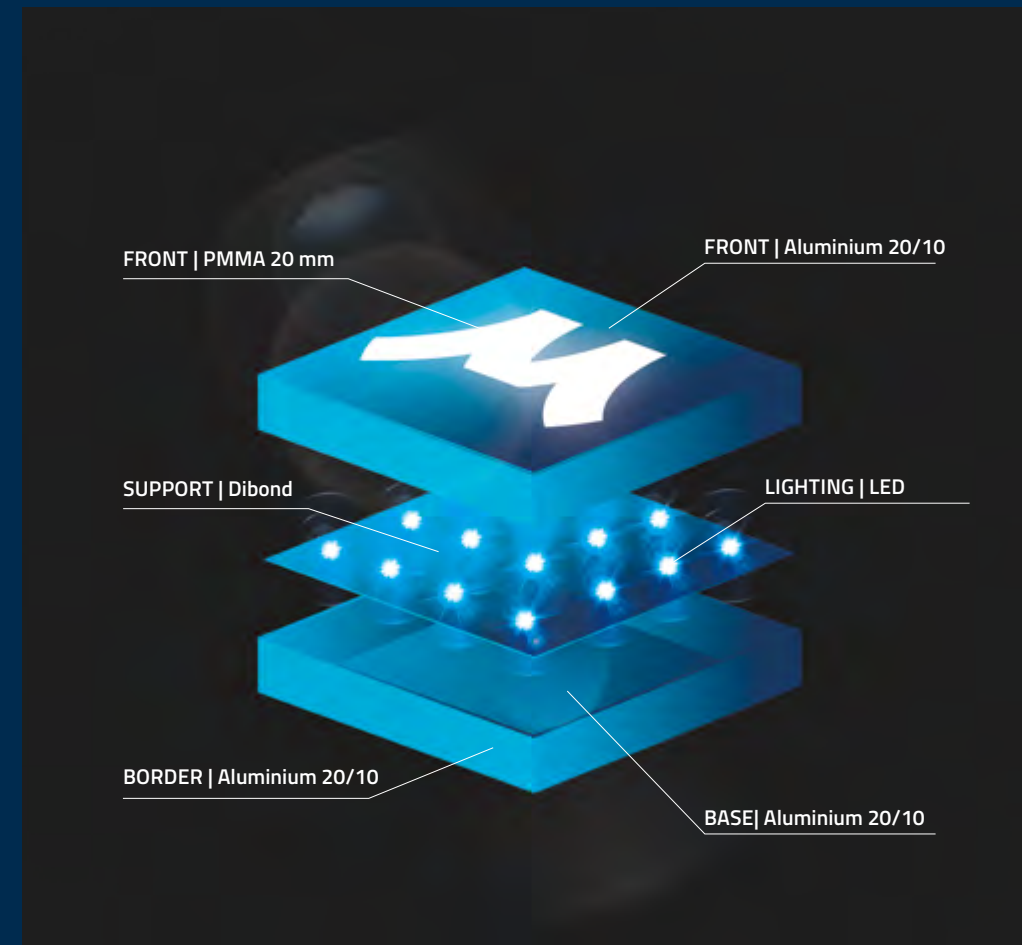

Usage: indoor and outdoor  
Size: small / medium / large  
Certification: CE



## PERFORATED PLUS

Single/double-sided perforated box with embossed solid wood lighting

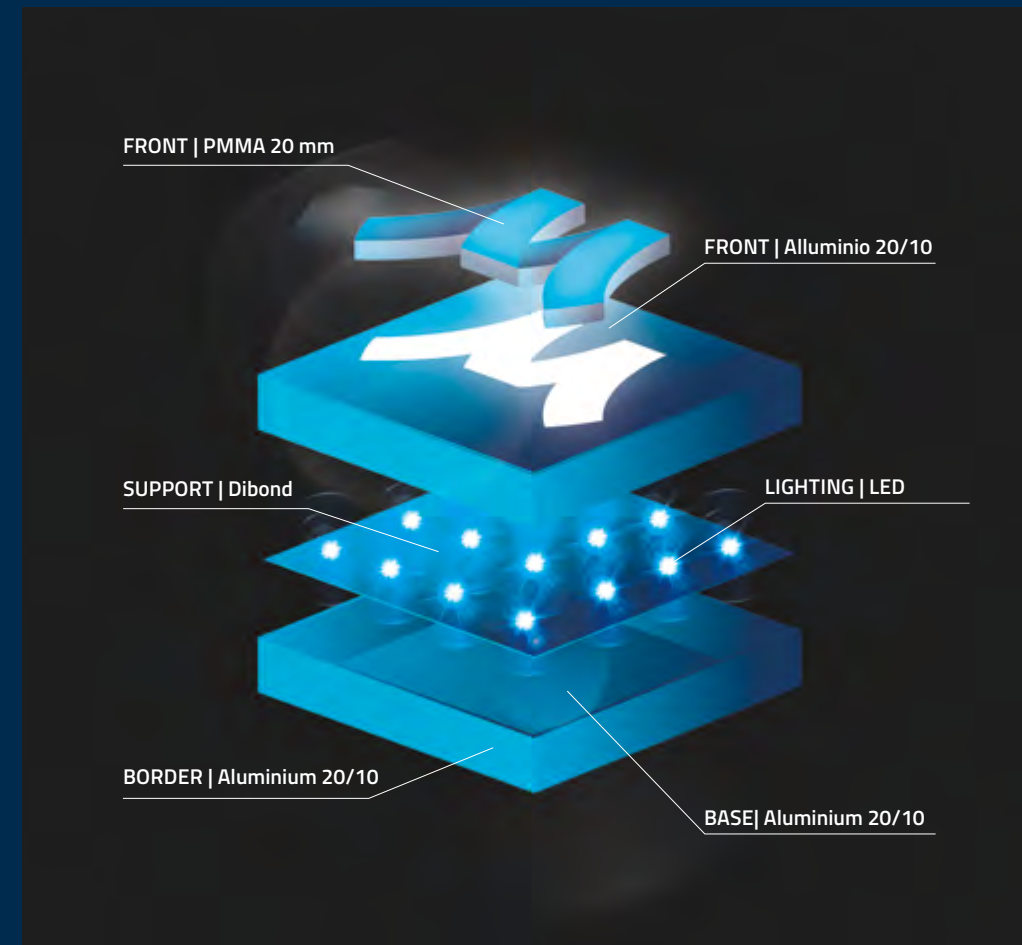

Usage: indoor and outdoor  
Size: small / medium / large  
Certification: CE





## LIGHTBOX

Single-sided lightbox with fully luminous custom fabric



Use: internal  
Size: small / medium / large  
Certification: CE



## DOUBLE-SIDE LIGHTBOX

Double-sided lightbox with fully luminous custom fabric



Use: internal  
Size: small / medium / large  
Certification: CE





## WASHINGTON

Single-sided box with fully luminous PVC sheet

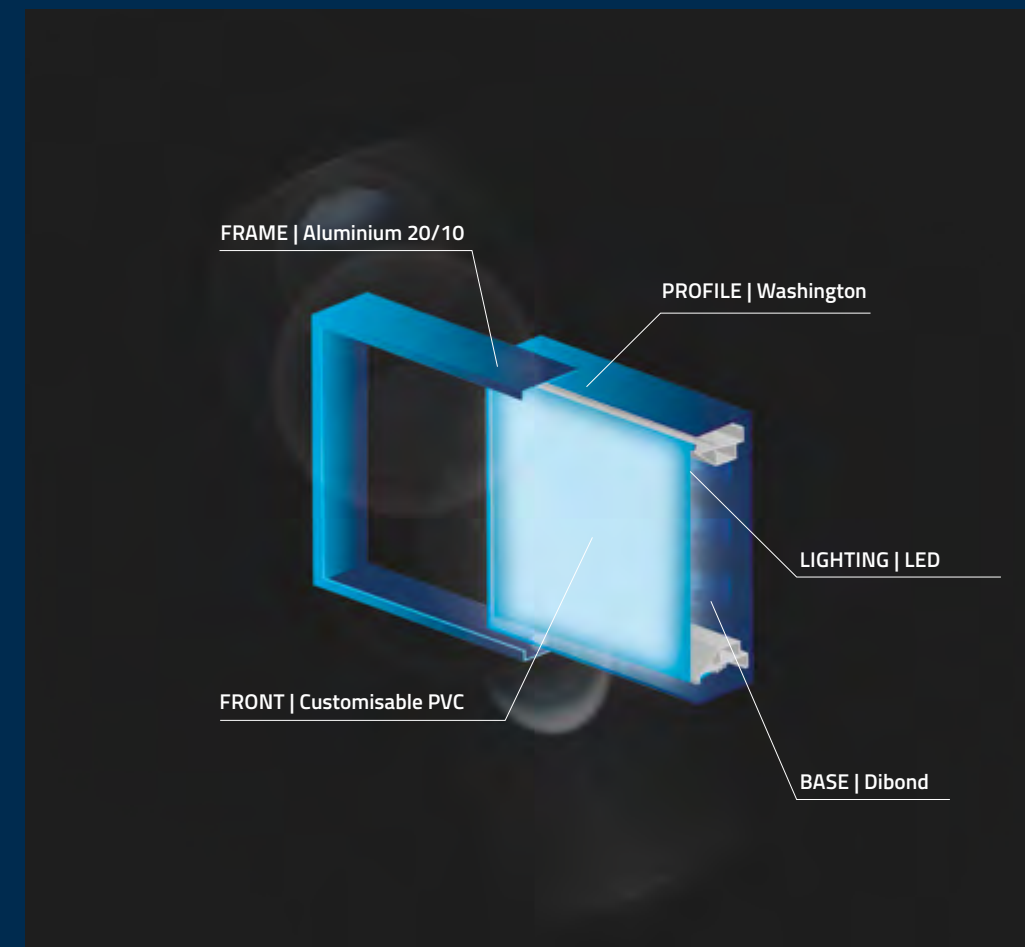

Usage: indoor and outdoor  
Size: medium / large  
Certification: CE



Large size



## TIRANA

Shaped single-sided box with fully luminous PVC sheet

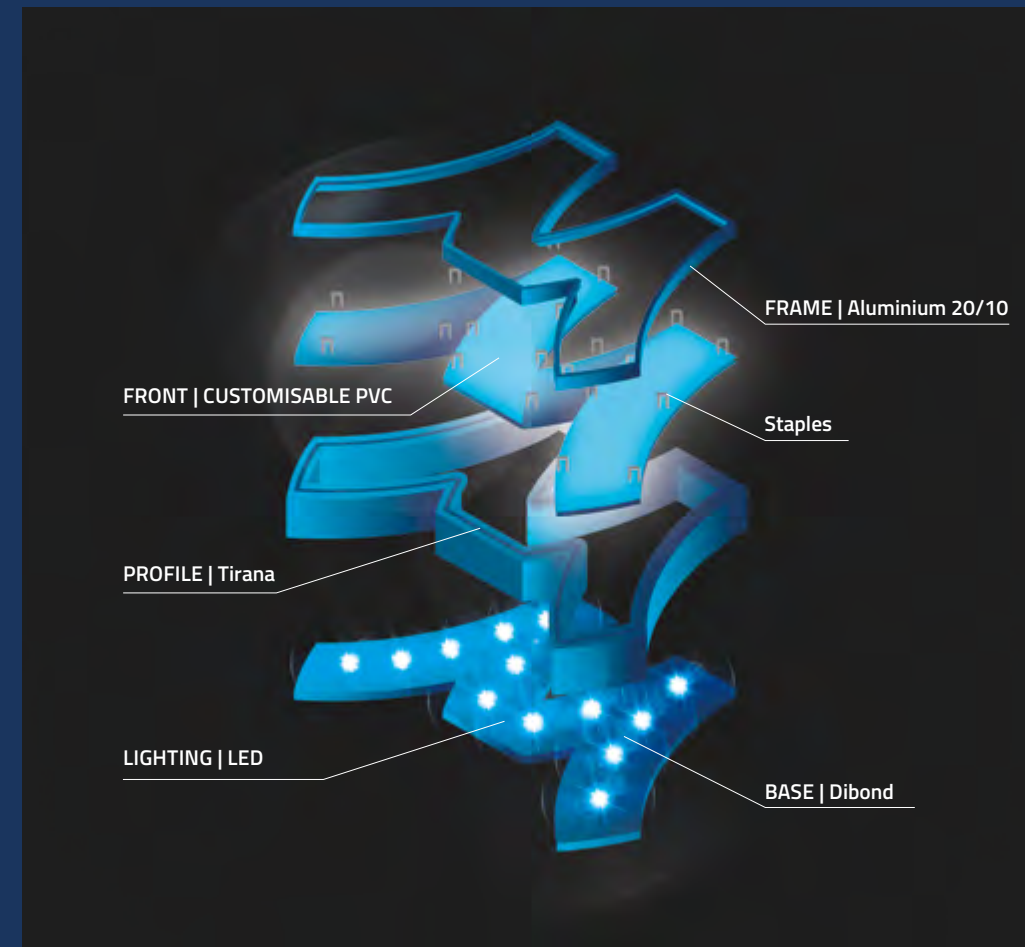

Usage: indoor and outdoor  
Size: medium / large  
Certification: CE





Large size



## ATENE

Single-sided frame with PVC sheet illuminated by spotlights

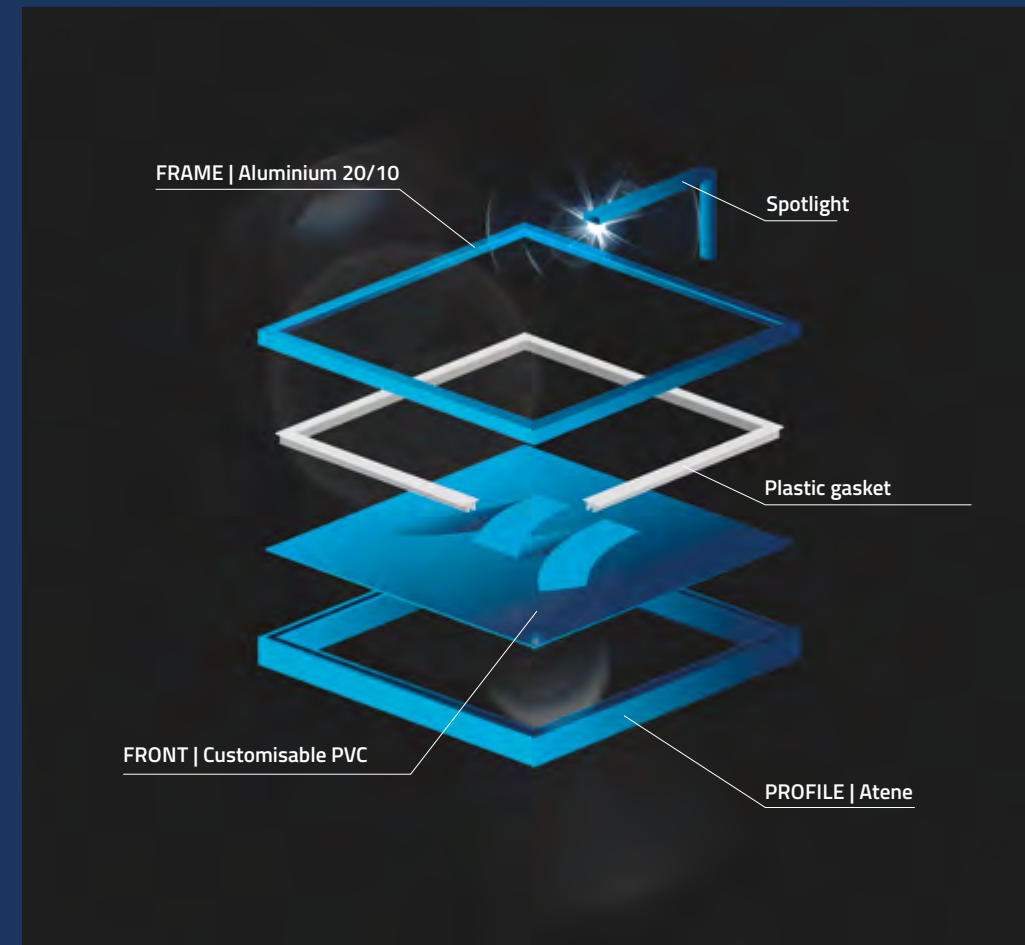

57

Usage: indoor and outdoor

Size: medium / large

Certification: CE



Large size



## LAELLE

Boxed sign with luminous front and perimeter frame

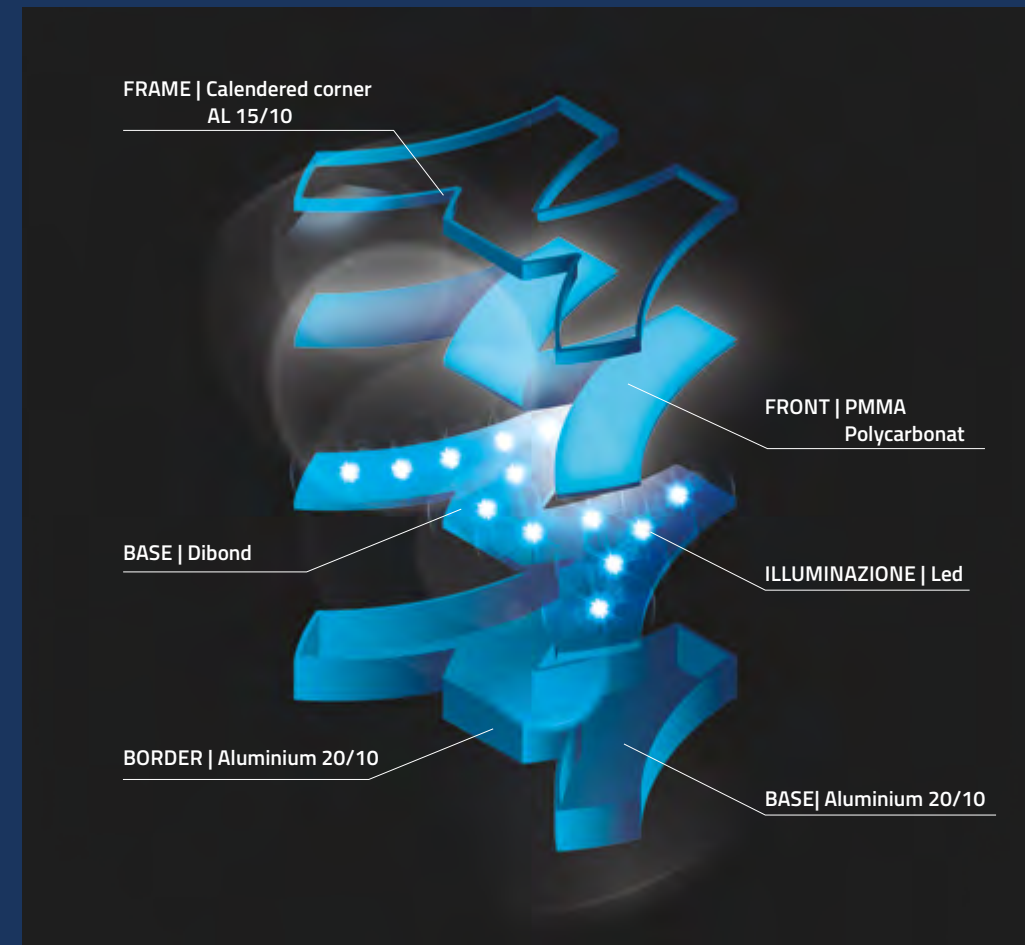

59

Usage: indoor and outdoor

Size: medium / large

Certification: CE





Outdoor various



## REKLAM

Blind hoardings lit by spotlights.

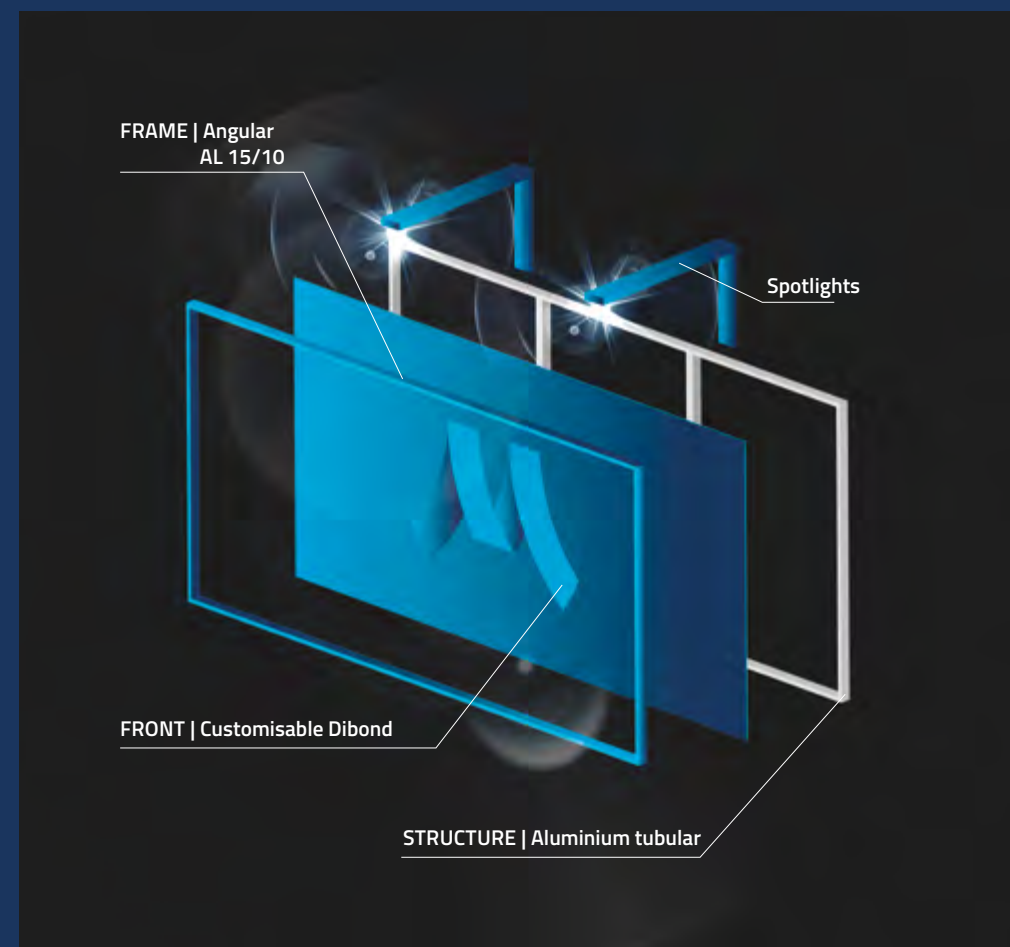

Use: indoor and outdoor.  
Dimensions: small / medium / large

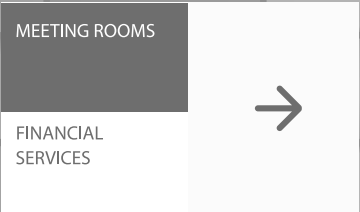
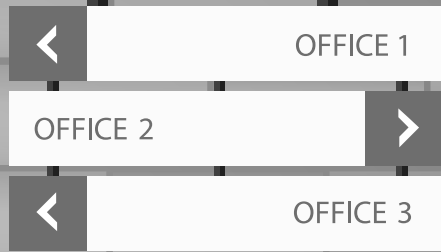
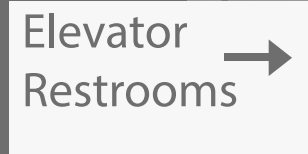

# Totem

Fully customisable totems, blind or luminous.

Usage: indoor and outdoor Size: small / medium / large  
Certification: CE

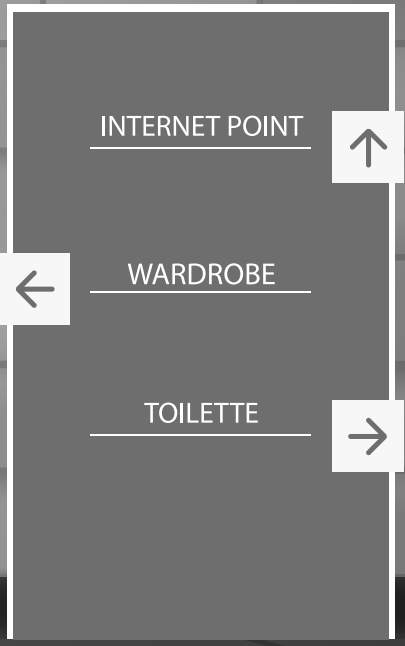
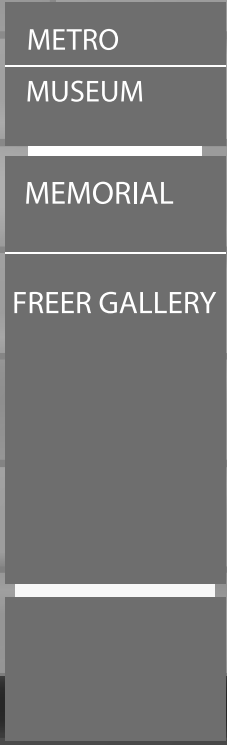
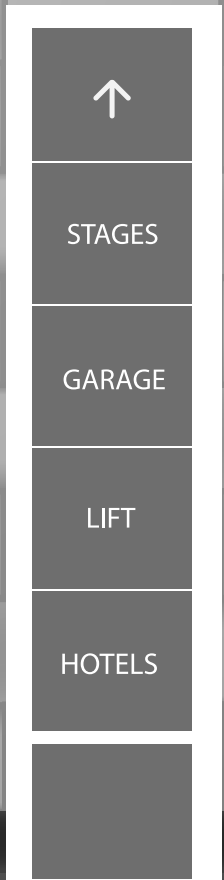
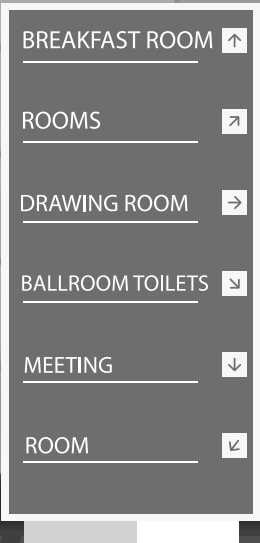
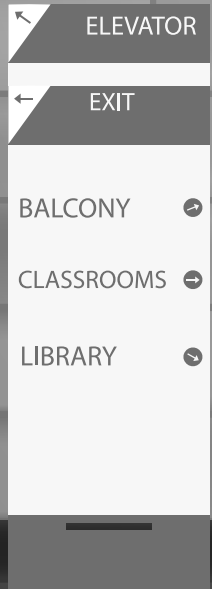
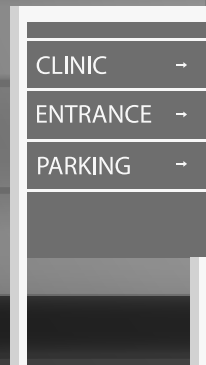



# SIGNS

LUMINA

## Light up your business

We are the perfect partner for your light communication. Thanks to our engineering know-how we are able to highlight textures and surfaces, providing a unique environment thanks to the indirect light effect.

Widely used for the production of signs, box letters or backlit totems, the products of the Lumina line will make your image shine out functionally and give your spaces maximum radiance, saving energy, all for the benefit of the environment





Direct light



## EXTRA MINI Single-sided

Operating voltage	DC 12V
Consumption	0.3 W
Light angle	120°
IP degree	IP 67
Operating temperature	-20°C +55°C
Recommended depth	from 30 to 50 mm
Module step	85 mm
Max connectable	50 pcs
Packaging	200 pcs
Warranty	3 years
Certifications	CE & Rohs

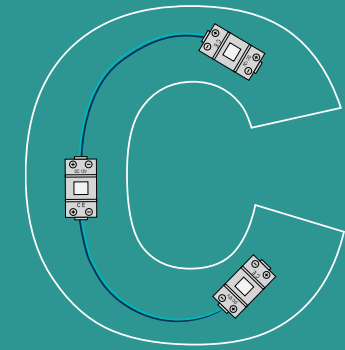

Small and medium-sized boxed letters.  
Backlighting of single-sided signs  
from 30 to 50 mm.

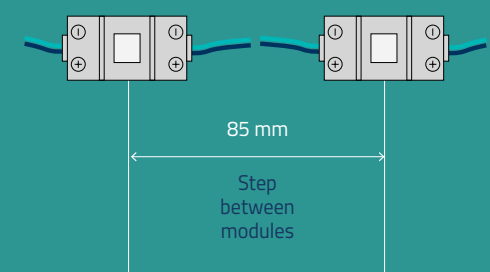
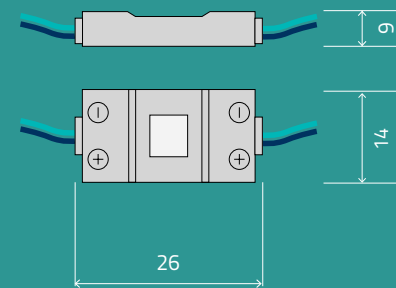

Code	Colour	Colour temperature	Lumen (lm)	Consumption (W/pc)	Current (A/pc)	Operating voltage
LU-1L-EXTRAMINI-PW	White	6500K	20	0.3	0.025	DC 12V





Direct light

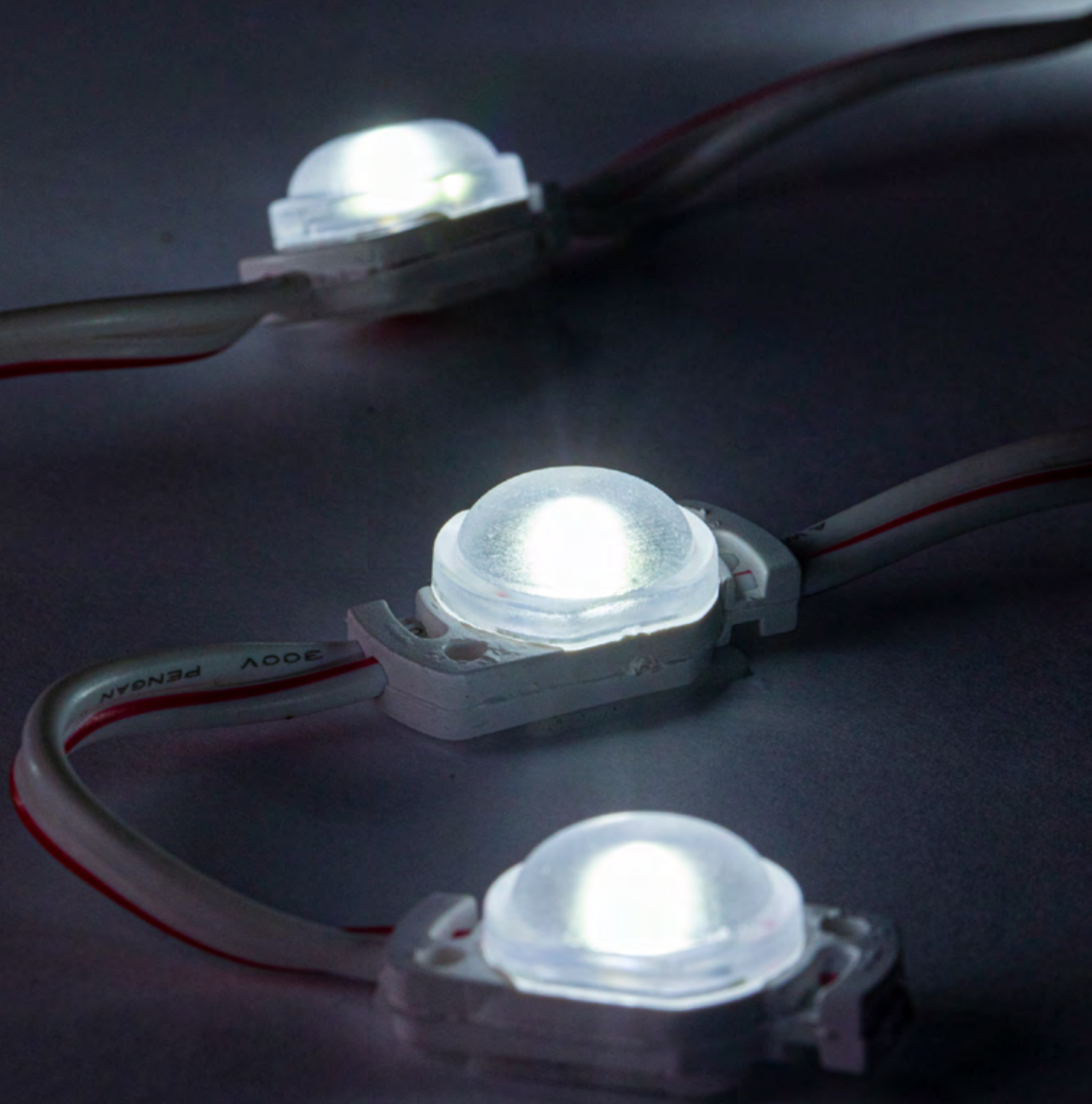

## ONE MINI Single-sided

Operating voltage	DC 12V
Consumption	0.48W
Light angle	170°
IP degree	IP 67
Operating temperature	-20°C +55°C
Recommended depth	from 30 to 80 mm
Modules step	86 mm
Max connectable	40 pcs
Packaging	200 pcs
Warranty	3 years
Operating voltage	CE & Rohs

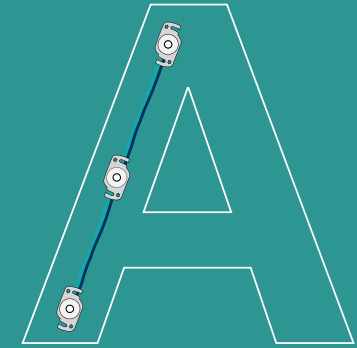

Small and medium-sized boxed letters.  
Backlighting of single-sided signs  
from 30 to 80 mm.

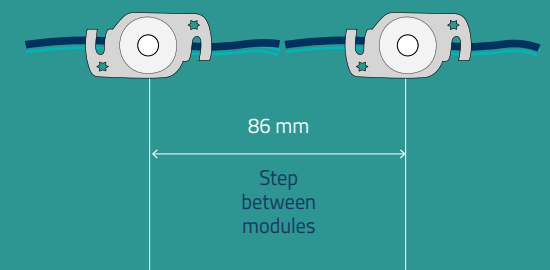
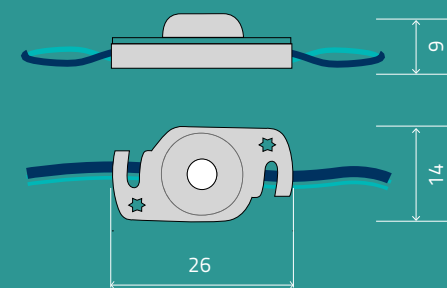

Code	Colour	Colour temperature	Lumen (lm)	Consumption (W/pc)	Current (A/pc)	Operating voltage
LU-1L-MINI-PW	White	6500K	40	0.48	0.04	DC 12V
LU-1L-MINI-CW	Cool White	10000K	40	0.48	0.04	DC 12V

Direct light



## BI REGULAR Single-sided

Operating voltage	DC 12V
Consumption	0.6W
Light angle	170°
IP degree	IP 67
Operating temperature	-20°C +55°C
Recommended depth	from 50 to 120 mm
Modules step	165,8 mm
Max connectable	40 pcs
Packaging	200 pcs
Warranty	3 years
Certifications	CE & Rohs

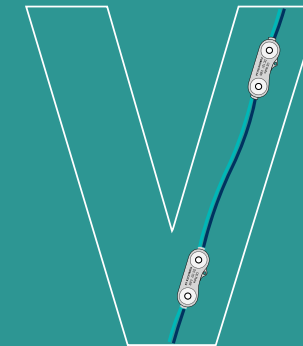

Medium sized boxed letters.  
Backlighting of single-sided signs  
from 50 to 120 mm.

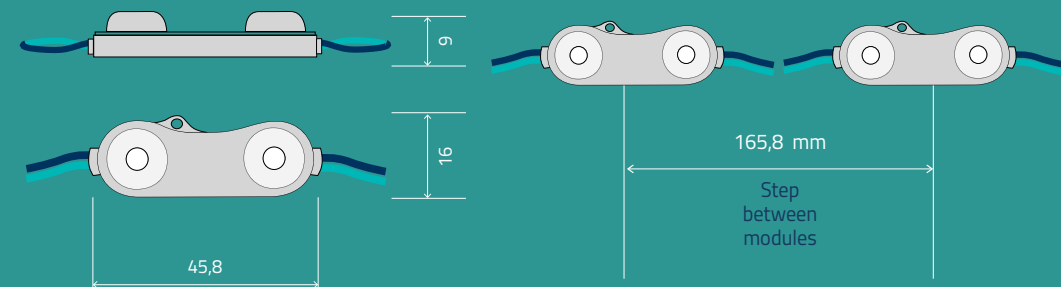

Code	Colour	Colour temperature	Lumen (lm)	Consumption (W/pc)	Current (A/pc)	Operating voltage
LU-2L-REG-PW	White	6500K	90	0.6	0.05	DC 12V
LU-2L-REG-CW	Cool White	10000K	90	0.6	0.05	DC 12V
LU-2L-REG-R	Red	620nm	80	0.6	0.05	DC 12V
LU-2L-REG-G	Green	520nm	80	0.6	0.05	DC 12V
LU-2L-REG-G	Blue	465nm	80	0.6	0.05	DC 12V





Direct light

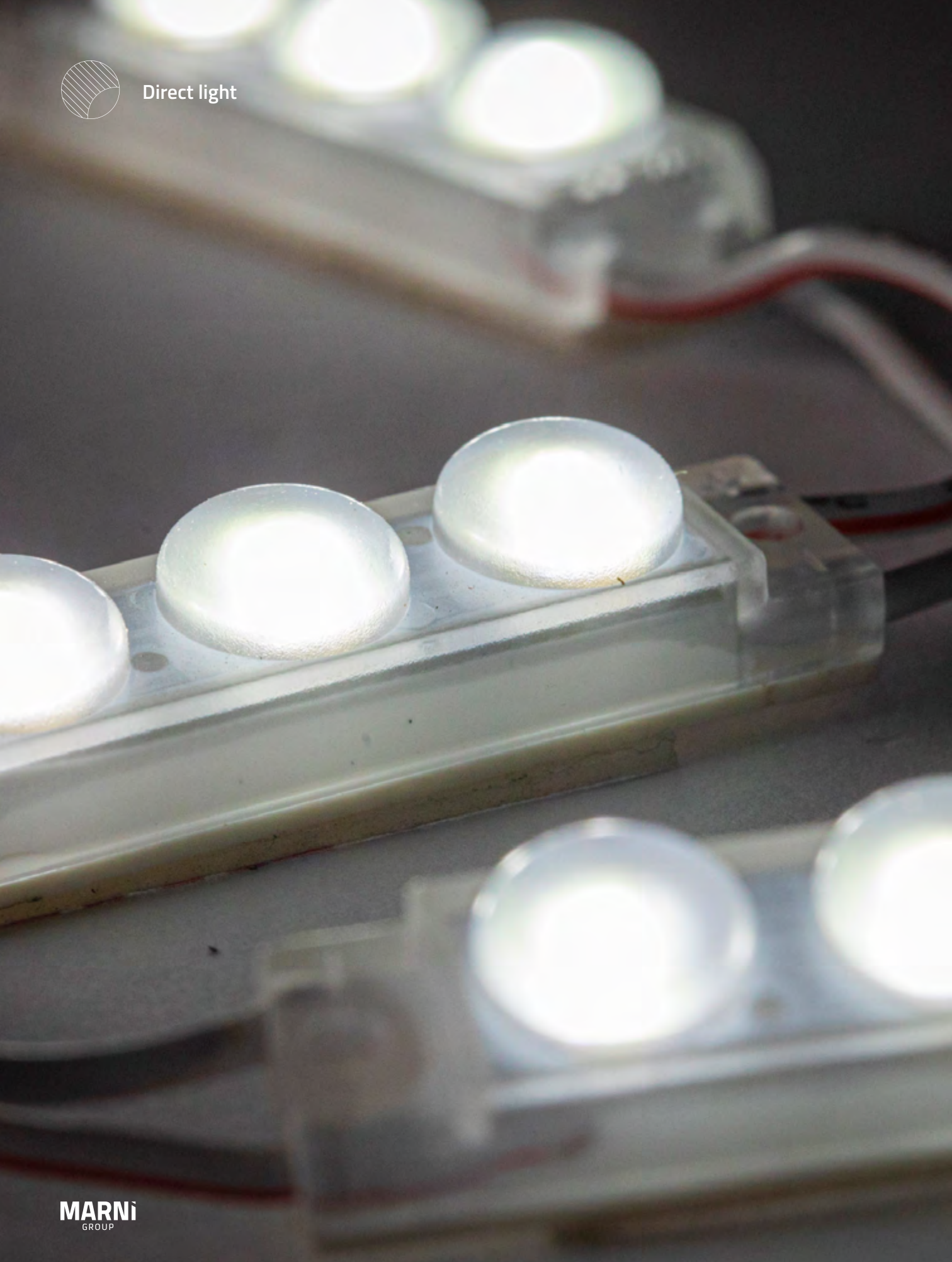

## TRIS MINI Single-sided

Operating voltage	DC 12V
Consumption	0.48W
Light angle	160°
IP degree	IP 67
Operating temperature	-20°C +55°C
Recommended depth	from 50 to 120 mm
Modules step	101 mm
Max connectable	20 pcs
Packaging	200 pcs
Warranty	3 years
Certifications	CE & Rohs

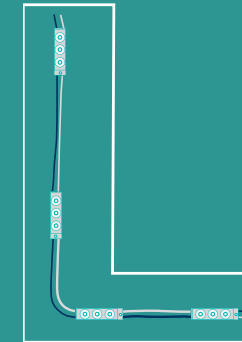

Small and medium-sized boxed letters.  
Backlighting of single-sided signs  
from 50 to 120 mm.

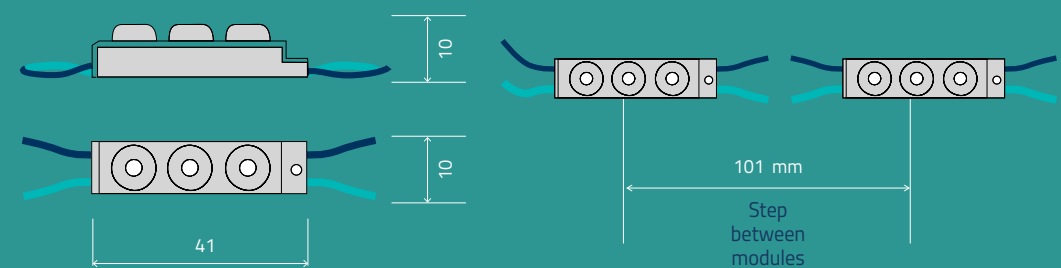

Codice	Colore	Temperatura colore	Lumen (lm)	Consumo (W/pc)	Corrente (A/pc)	Tensione d'esercizio
LU-3L-MINI-PW	White	6500K	60	0.48	0.04	DC 12V
LU-3L-MINI-CW	Cool White	10000K	60	0.48	0.04	DC 12V

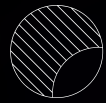

Direct light



## TRIS REGULAR Single-sided

Operating voltage	DC 12V
Consumption	0.9W
Light angle	170°
IP degree	IP 67
Operating temperature	-20°C +55°C
Recommended depth	from 80 to 200 mm
Modules step	211,5 mm
Max connectable	20 pcs
Packaging	100 pcs
Warranty	3 years
Certifications	CE & Rohs

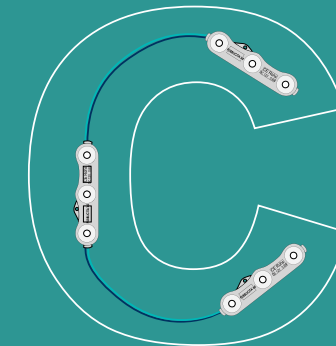

Medium sized boxed letters.  
Backlighting of single-sided signs  
from 80 to 200 mm.

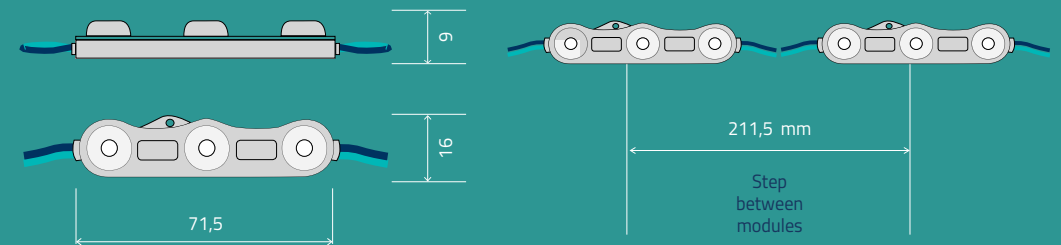

Code	Colour	Colour temperature	Lumen (lm)	Consumption (W/pc)	Current (A/pc)	Operating voltage
LU-3L-REG-PW	White	6500K	135	0.9	0.075	DC 12V
LU-3L-REG-CW	Cool White	10000K	135	0.9	0.075	DC 12V
LU-3L-REG-R	Red	620nm	135	0.9	0.075	DC 12V
LU-3L-REG-G	Green	520nm	135	0.9	0.075	DC 12V
LU-3L-REG-B	Blue	465nm	135	0.9	0.075	DC 12V



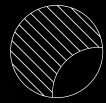

Direct light



## Q REGULAR Single-sided

Operating voltage	DC 12V
Consumption	1.4W
Light angle	170°
IP degree	IP 67
Operating temperature	-20°C +55°C
Recommended depth	from 80 to 300 mm
Step modules	285,6 mm
Max connectable	20 pcs
Packaging	100 pcs
Warranty	3 years
Certifications	CE & Rohs

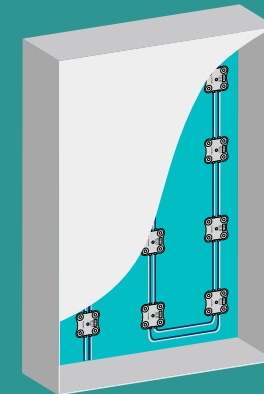

Medium sized boxed letters.  
Backlighting of single-sided signs  
from 80 to 300 mm.

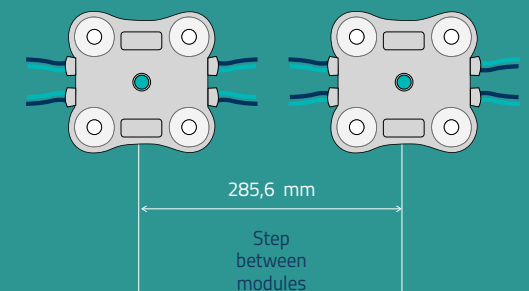
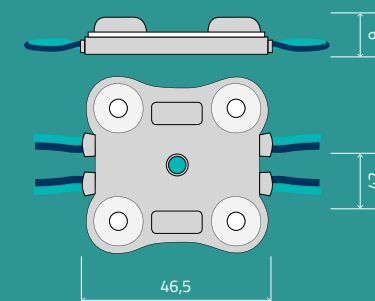

Code	Colour	Colour temperature	Lumen (lm)	Consumption (W/pc)	Current (A/pc)	Operating voltage
LU-4L-REG-PW	White	6500K	180	1.4	0.12	DC 12V
LU-4L-REG-CW	Cool White	10000K	180	1.4	0.12	DC 12V
LU-4L-REG-R	Red	620nm	150	1.4	0.12	DC 12V
LU-4L-REG-G	Green	520nm	150	1.4	0.12	DC 12V
LU-4L-REG-B	Blue	465nm	150	1.4	0.12	DC 12V



Direct light

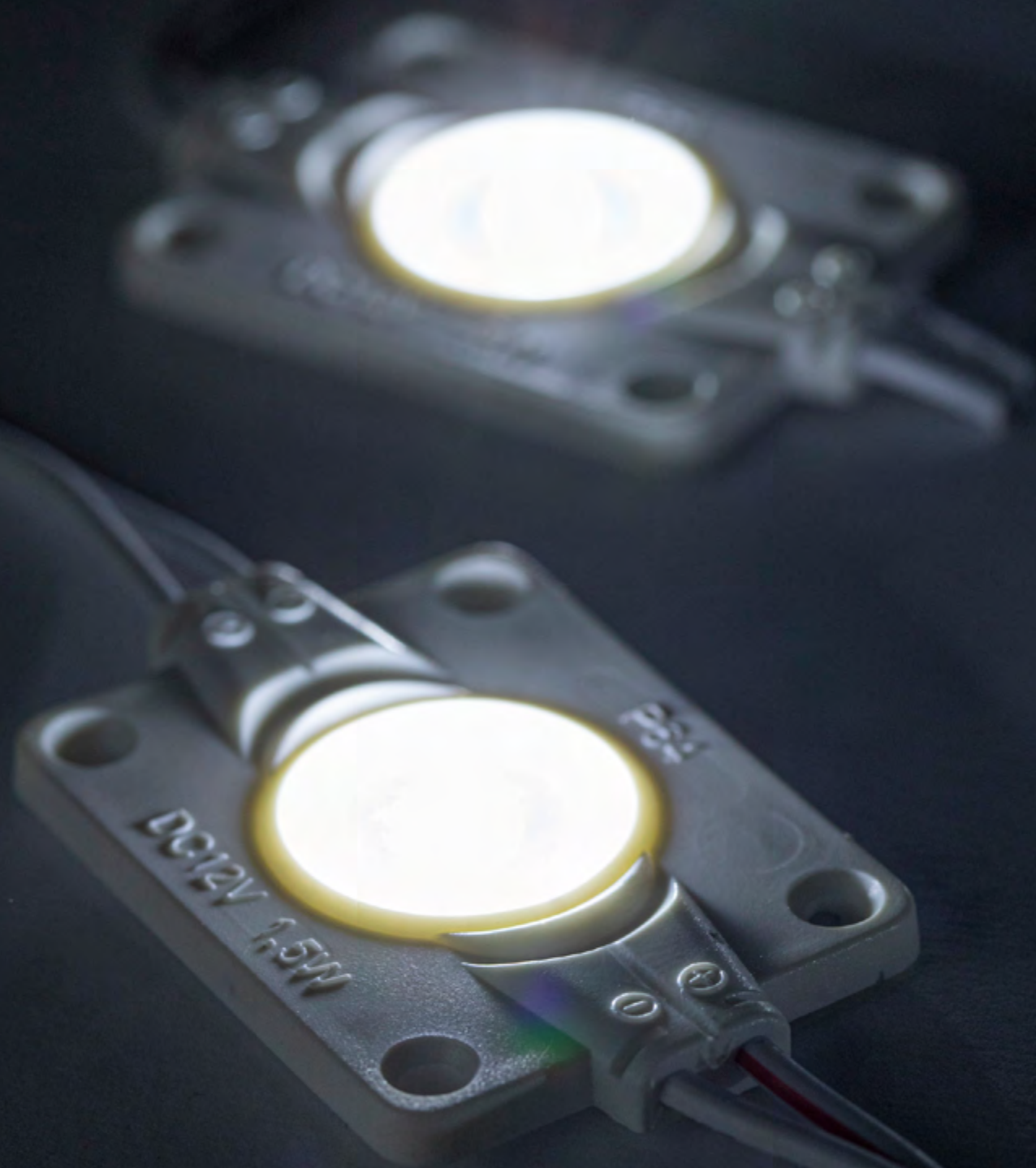

## ONE REGULAR Single-sided

Operating voltage	DC 12V
Consumption	1.5W
Light angle	160°
IP degree	IP 65
Operating temperature	-20°C +55°C
Recommended depth	from 80 to 300 mm
Step modules	253 mm
Max connectable	20 pcs
Packaging	100 pcs
Warranty	3 years
Certifications	CE & Rohs

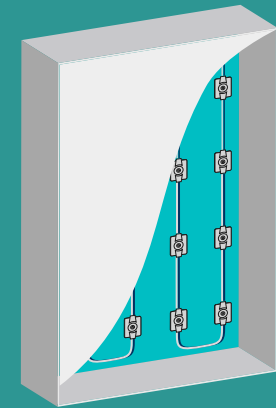

Medium sized boxed letters.  
Backlighting of single-sided signs  
from 80 to 300 mm.

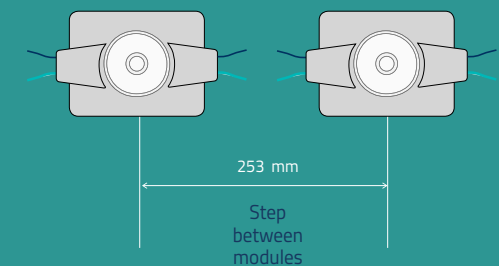
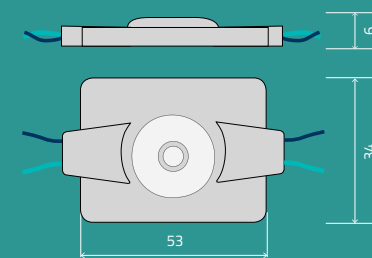

Code	Colour	Colour temperature	Lumen (lm)	Consumption (W/pc)	Current (A/pc)	Operating voltage
LU-1L-REG-PW	White	6500K	150	1.5	0.125	DC 12V
LU-1L-REG-CW	Cool White	10000K	150	1.5	0.125	DC 12V





Direct light

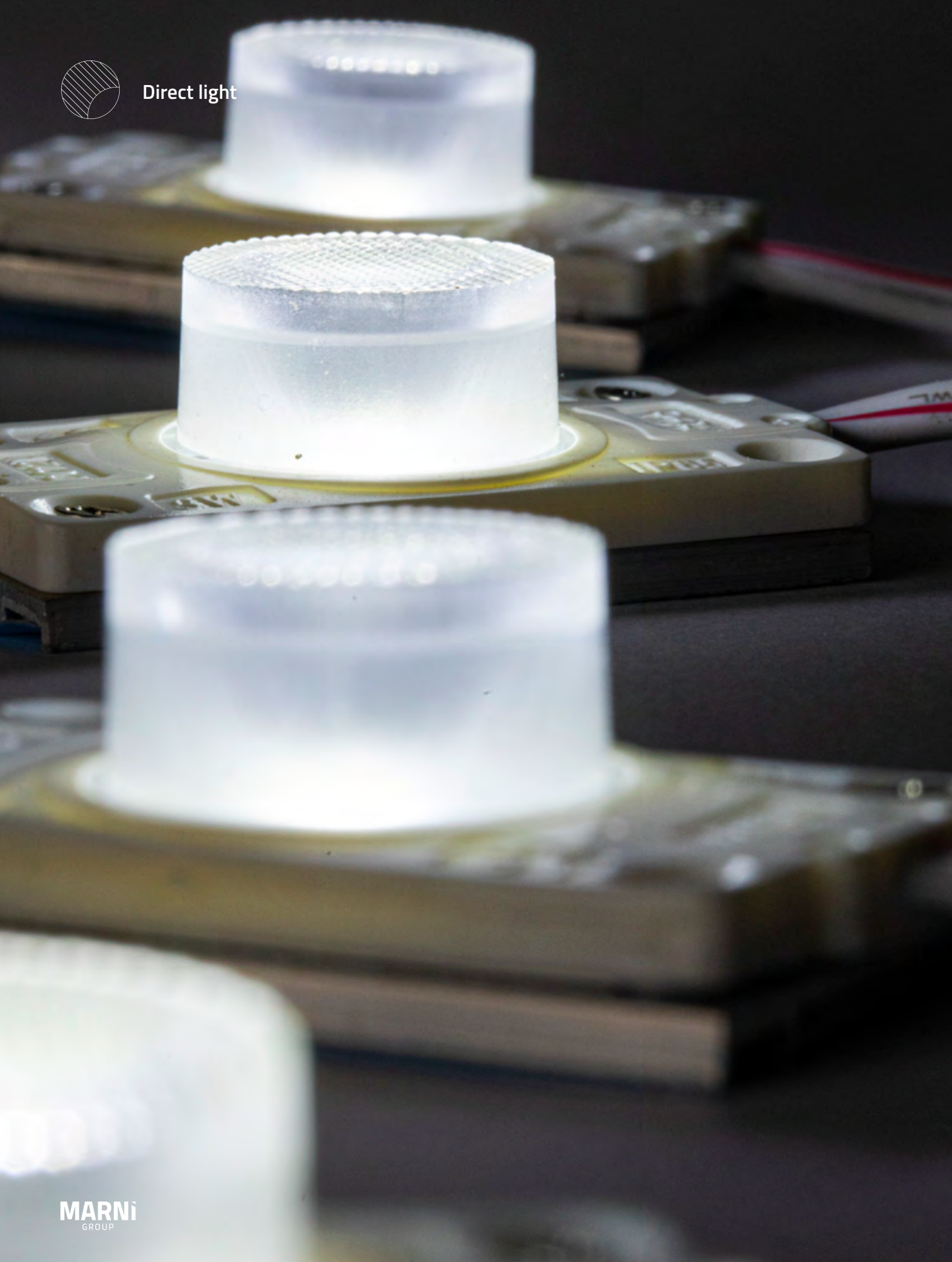

## ONE EXTRA Double-sided

Operating voltage	DC 12V
Consumption	3W
Light angle	45°
IP degree	IP 67
Operating temperature	-20°C +55°C
Recommended depth	up to 4000 mm
Step modules	204 mm
Max connectable	20 pcs
Packaging	100 pcs
Warranty	3 years
Certifications	CE & Rohs

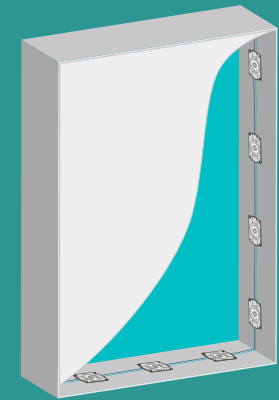

Double-sided boxes and totem up to 4000 mm

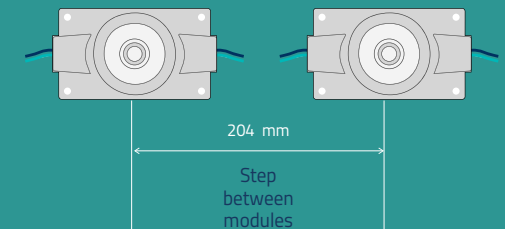
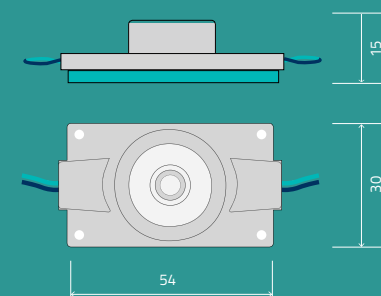

Code	Colour	Colour temperature	Lumen (lm)	Consumption (W/pc)	Current (A/pc)	Operating voltage
LU-1L-EXTRA-3W	White	6500K	200	3	0.25	DC 12V



Direct light



## ONE PLUS Double-sided

Operating voltage	DC 12V
Consumption	2W
Light angle	45°
IP degree	IP 65
Operating temperature	-20°C +55°C
Recommended depth	up to 3000 mm
Step modules	194 mm
Max connectable	20 pcs
Packaging	100 pcs
Warranty	3 years
Certifications	CE & Rohs

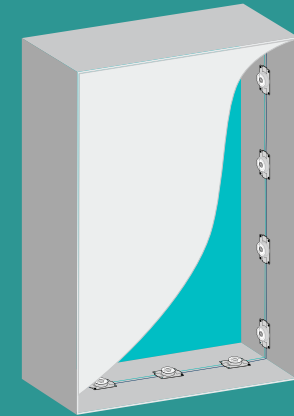

Double-sided boxes and totem up to 3000 mm

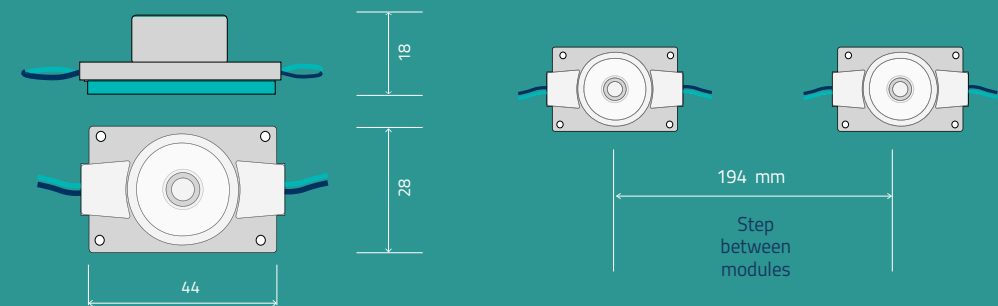

Code	Colour	Colour temperature	Lumen (lm)	Consumption (W/pc)	Current (A/pc)	Operating voltage
LU-1L-PLUS-2W	White	6500K	150	2	0.17	DC 12V





Direct light

## NEW CHAIN Internal single-sided

Operating voltage	DC 24V
Consumption	0.75W
Light angle	160°
IP degree	IP 20
Operating temperature	-20°C +55°C
Recommended depth	from 60 to 120 mm
Step modules	105 mm
Max connectable	20 pcs
Packaging	100 pcs
Warranty	3 years
Certifications	CE & Rohs

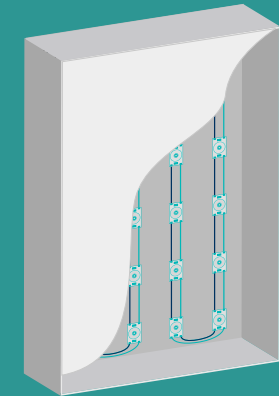

Medium sized boxed letters.  
Backlighting of single-sided signs  
from 60 to 120 mm.

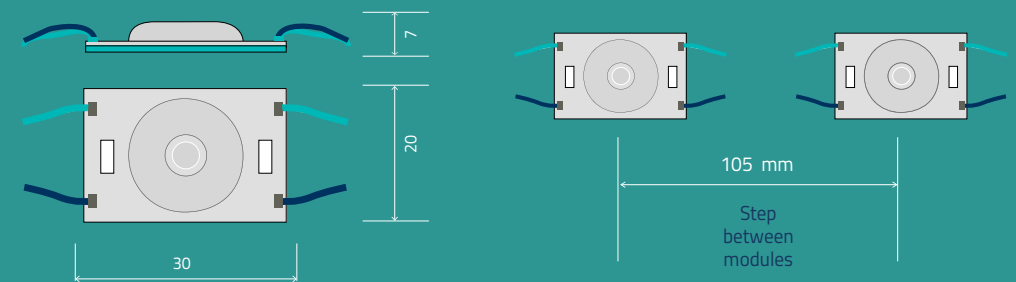

Code	Colour	Colour Temperature	Lumen (lm)	Consumption (W/pc)	Current (A/pc)	Operating voltage
LU-1L-NEWCHAIN-PW	White	6500K	100	0.75	0.0625	DC 24V



Direct light



## STRIP REGULAR Internal single-sided

Operating voltage	DC 24V
Consumption	4.8W/m
Light angle	120°
IP degree	IP 20
Operating temperatur	-20°C +55°C
Recommended depth	from 40 to 200 mm
Max connectable	5 m
Packaging	50 m/roll
Warranty	2 years
Certifications	CE & Rohs

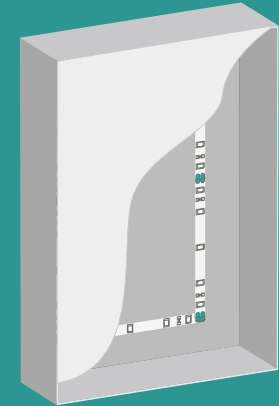

Medium sized boxed letters.  
Backlighting of single-sided signs  
from 40 to 200 mm

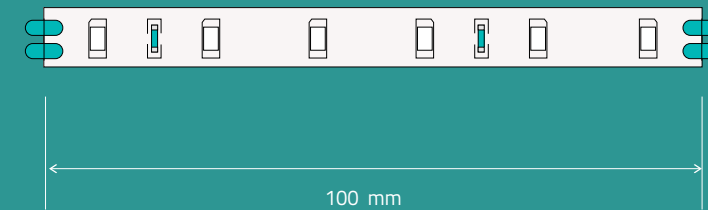

Code	Colour	Colour Temperature	Lumen (lm)	Consumption (W/pc)	Current (A/pc)	Operating voltag
LU-60L-STRIP-PW	White	6500K	22	4.8	0.4	DC 24V
LU-60L-STRIP-NW	Natural White	4000K	22	4.8	0.4	DC 24V
LU-60L-STRIP-WW	Warm White	3000K	22	4.8	0.4	DC 24V



# SIGNS

## PROFILIA

### Light, resistant, practical

The extruded aluminium profiles are 88 obtained by modelling aluminium bars at high temperatures, thus guaranteeing the creation of extremely resistant but at the same time light structures, responding to all the new market needs.

The extrusions marketed by us can be supplied with an anodised OX surface, white-black or painted with reference to the RAL colour chart.

Aluminium extrusions with anodised surface are more suitable if there is a need for greater protection from potentially harmful external agents. The extruded aluminium with painted surface are instead recommended where there are particular aesthetic requirements.







## Londra 21 Single-sided

Extruded aluminium profile for fabric tensioning with rubber. Ideal for single-sided non-luminous small to medium-sized lightboxes for wall mounting.

Available colours:



RAL 9003 RAL 9005 RAL 9006

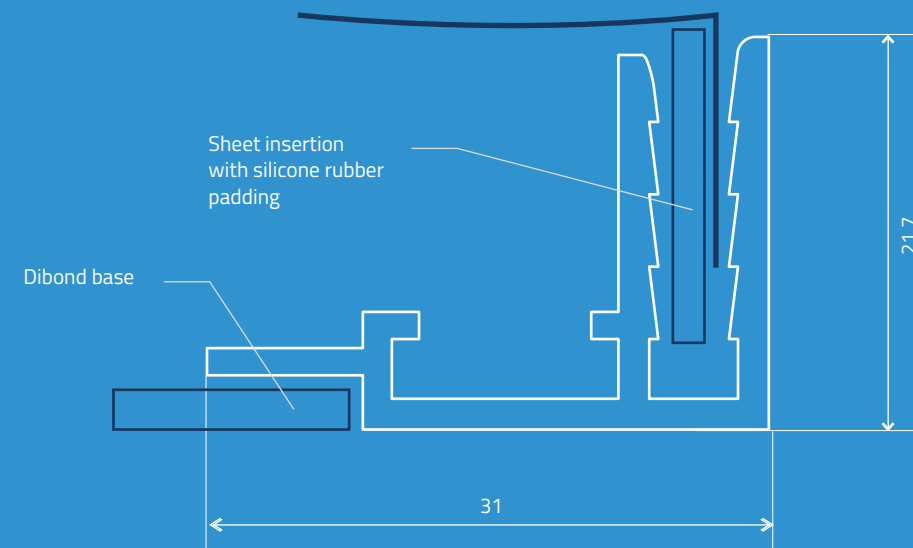



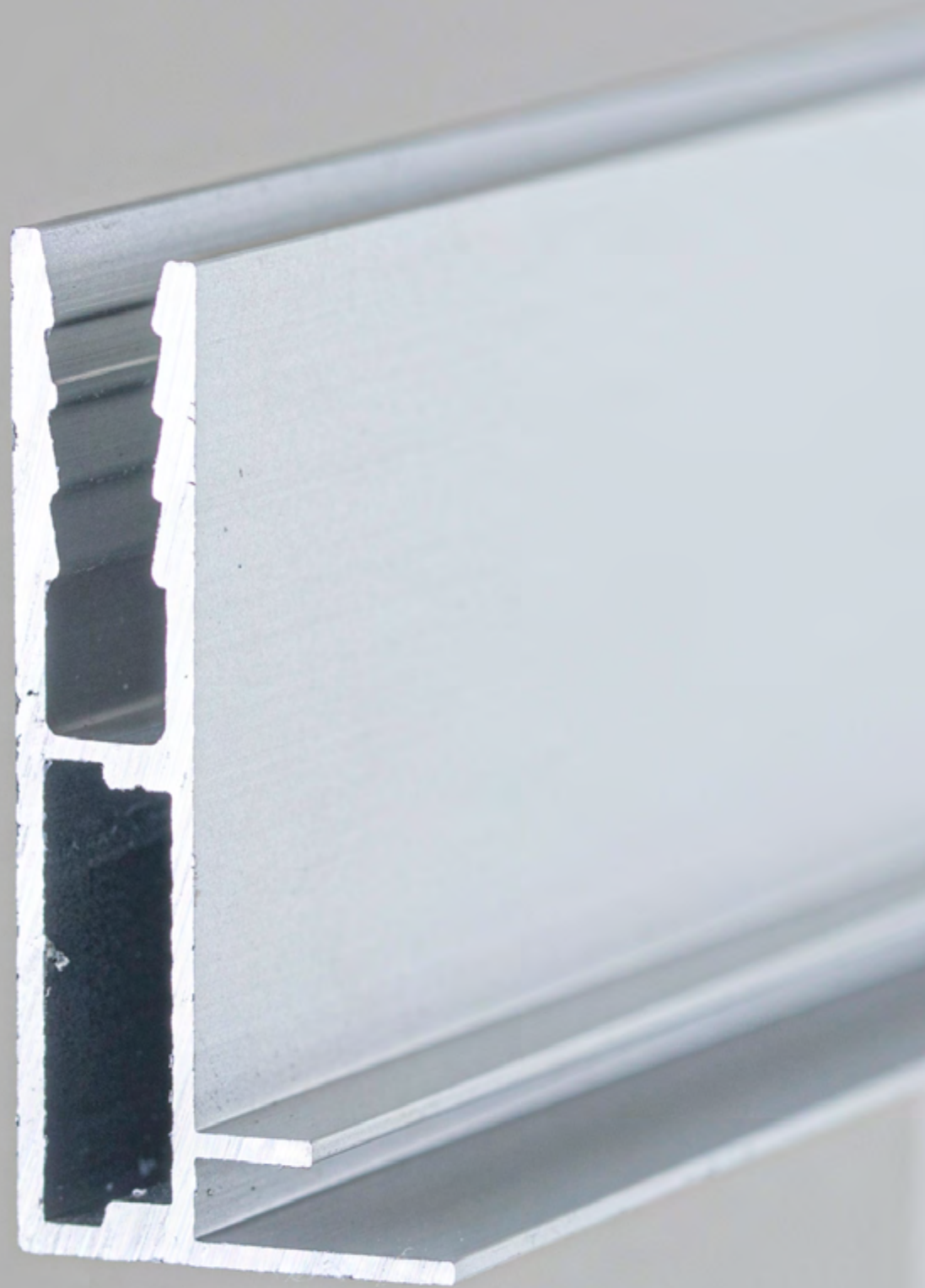

## Londra 40 Single-sided

Extruded aluminium profile for fabric tensioning with rubber. Ideal for medium-sized luminous single-sided lightboxes for wall mounting.

Available colours:



RAL 9003 RAL 9005 RAL 9006

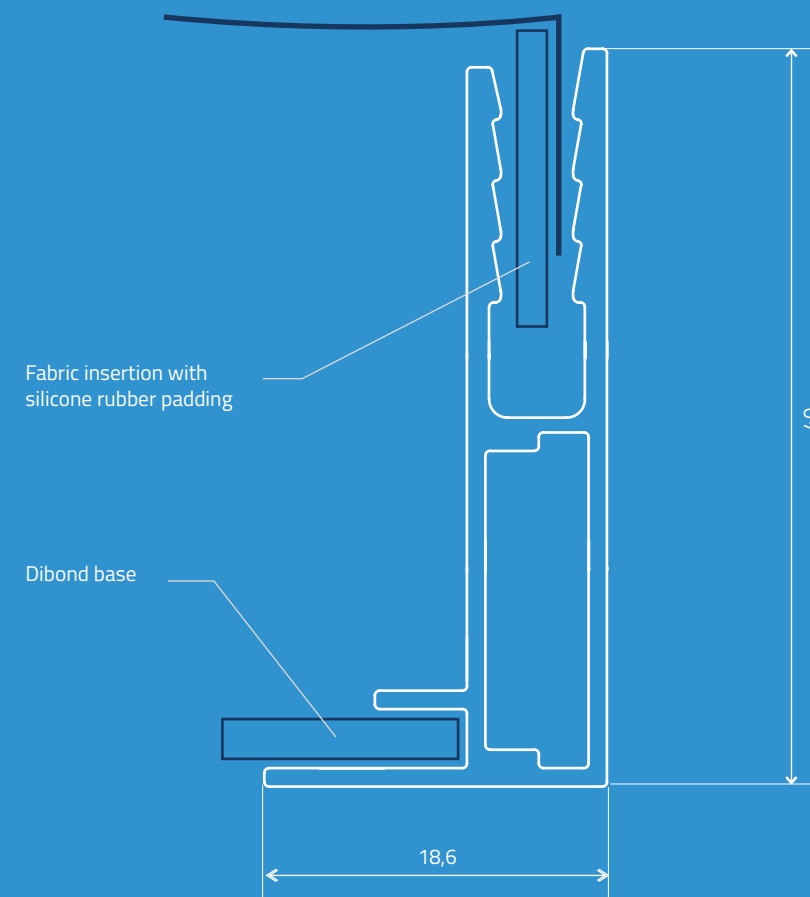



## Londra 64 Single-sided

Extruded aluminium profile for fabric tensioning with rubber. Ideal for medium and large sized luminous single-sided lightboxes for wall mounting.

Available colours:



RAL 9003 RAL 9005 RAL 9006

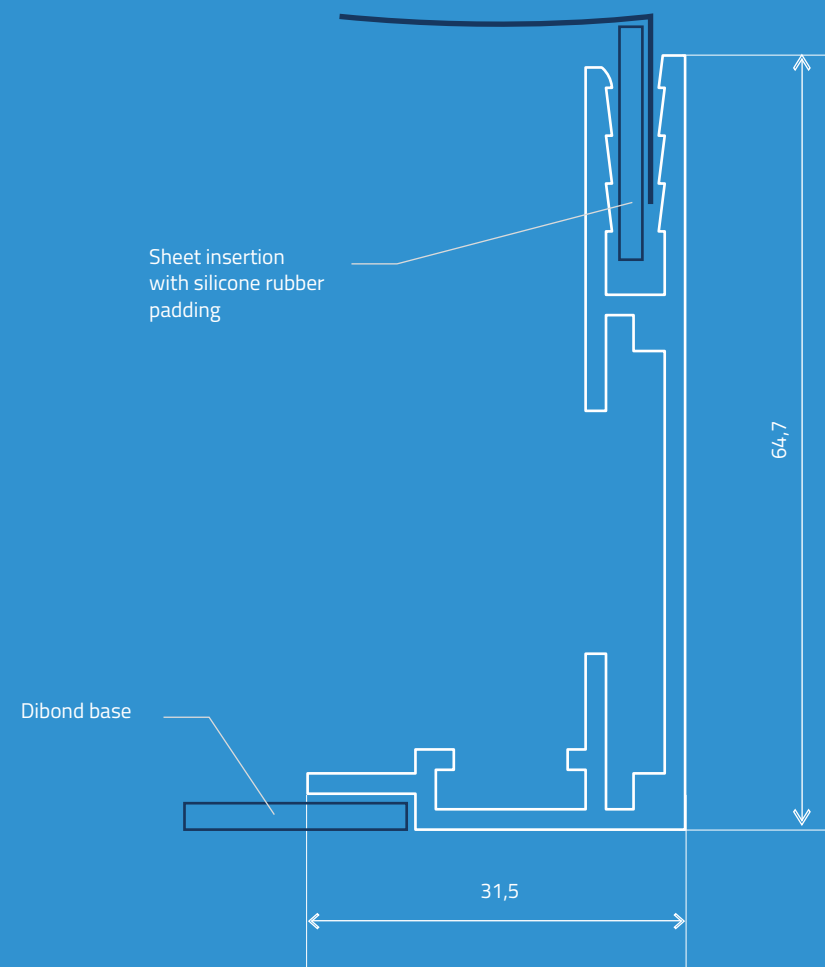





## Londra 100 Single-sided

Extruded aluminium profile for fabric tensioning with rubber. Ideal for medium and large sized luminous single-sided lightboxes for wall mounting.

Available colours:

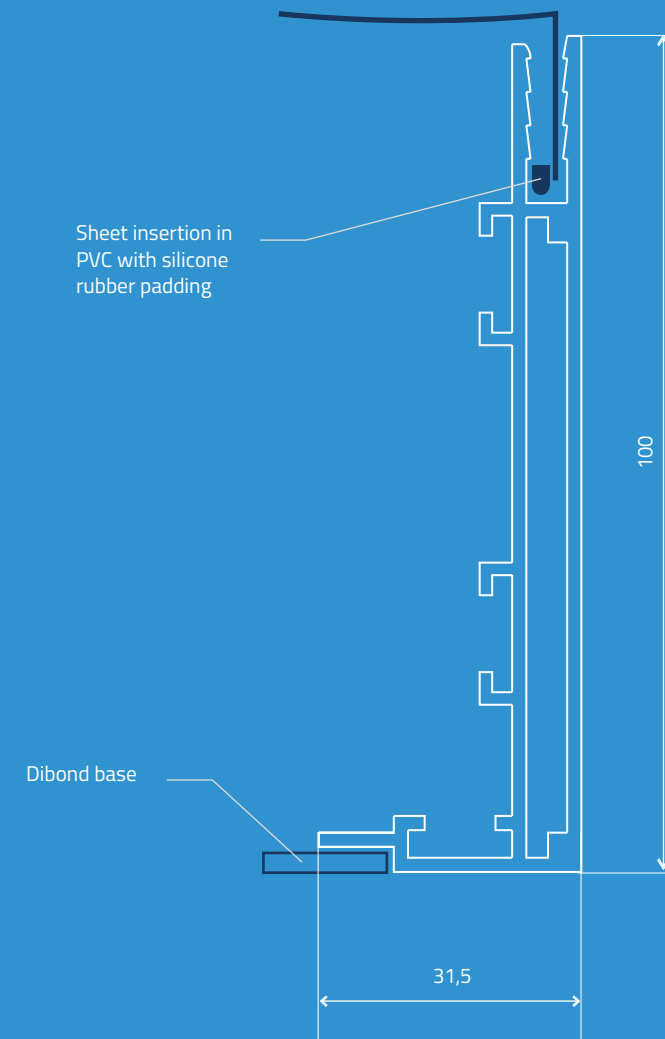
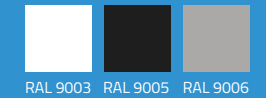

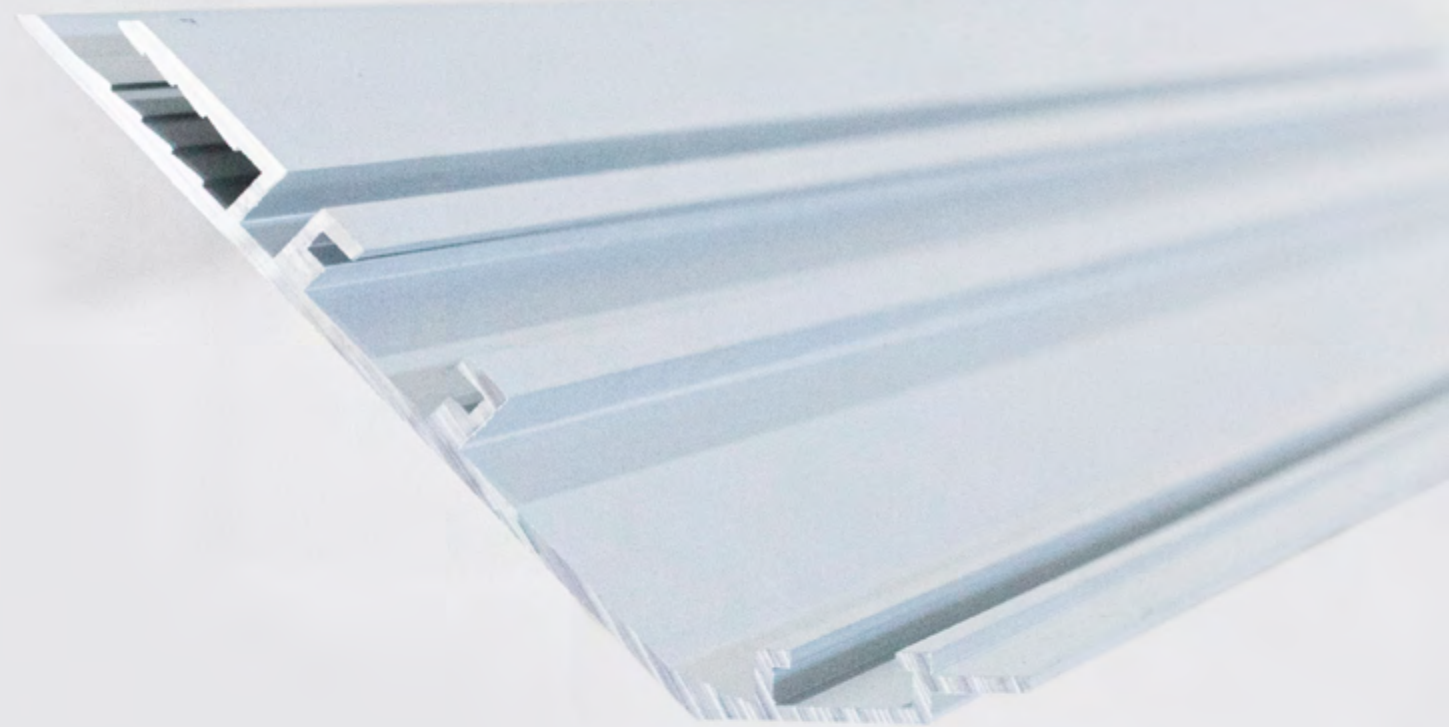

## Londra 45° Single-sided

Extruded aluminium profile for fabric tensioning with rubber. To create lightboxes that continue seamlessly around corners on walls or furniture.

Available colours:

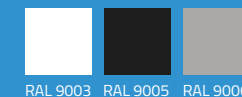

RAL 9003 RAL 9005 RAL 9006

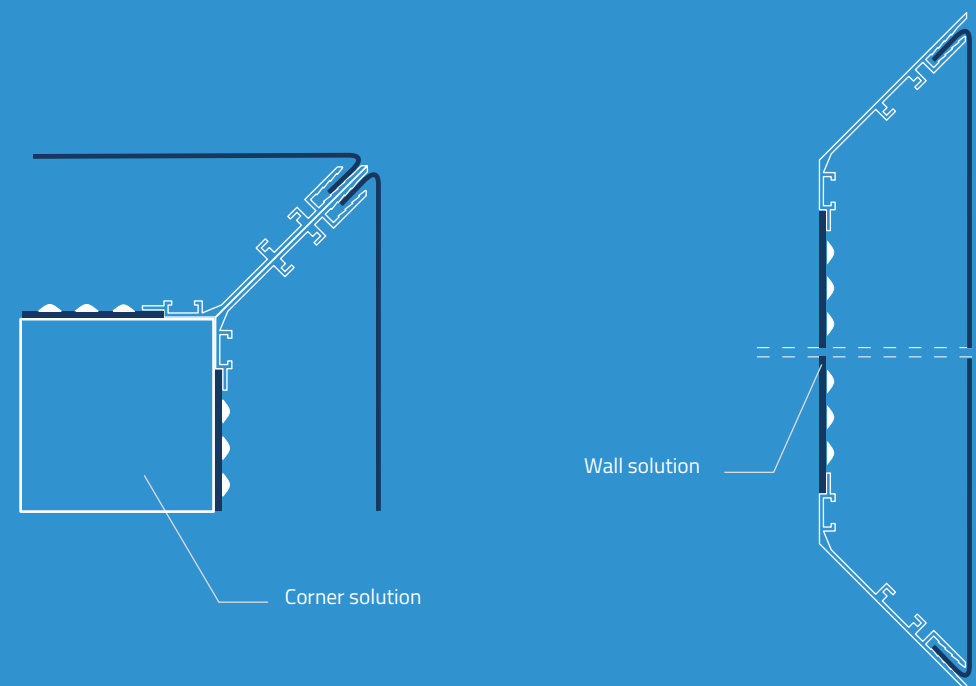
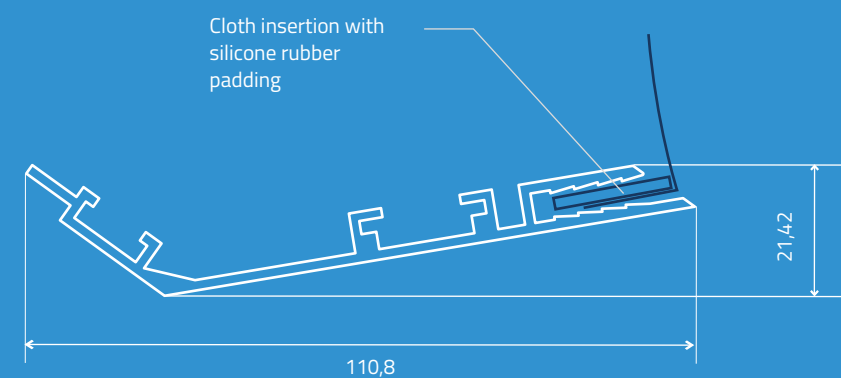





## Londra 50 Double-sided

Extruded aluminium profile for fabric tensioning with rubber. Ideal for small and medium-sized non-luminous double-sided lightboxes, suspended or self-supporting fixing.

Available colours:



RAL 9003 RAL 9005 RAL 9006

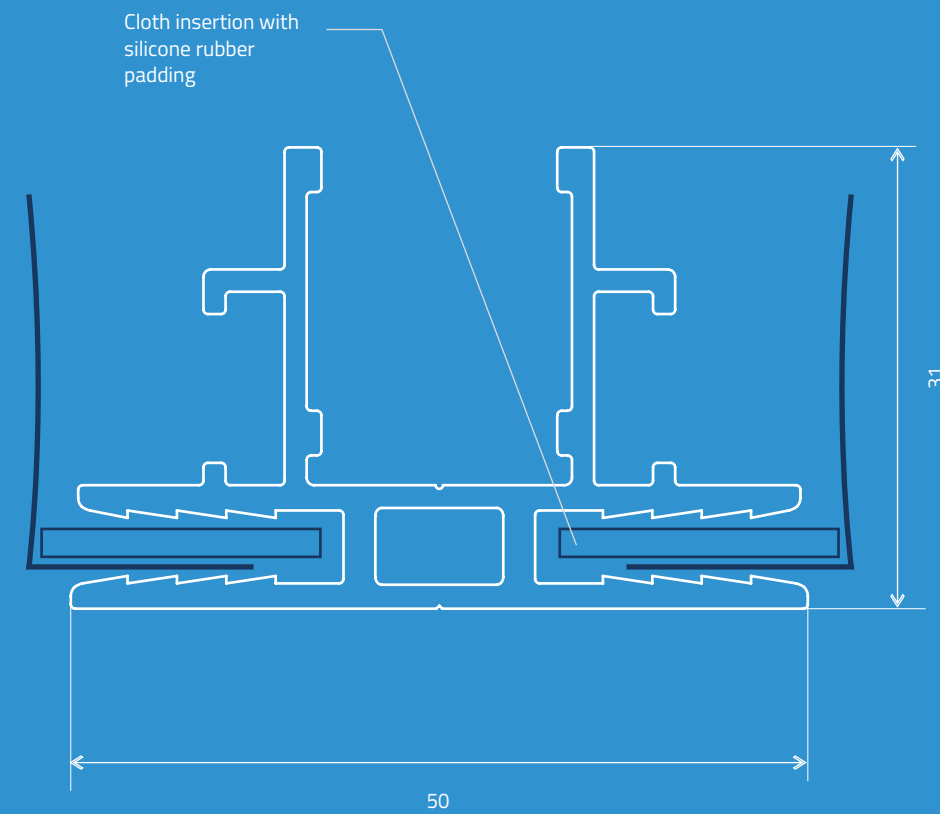



## Londra 100 Double-sided

Extruded aluminium profile for fabric tensioning with rubber. Ideal for small and medium-sized bright double-sided lightboxes, suspended or self-supporting fixing.

Available colours:

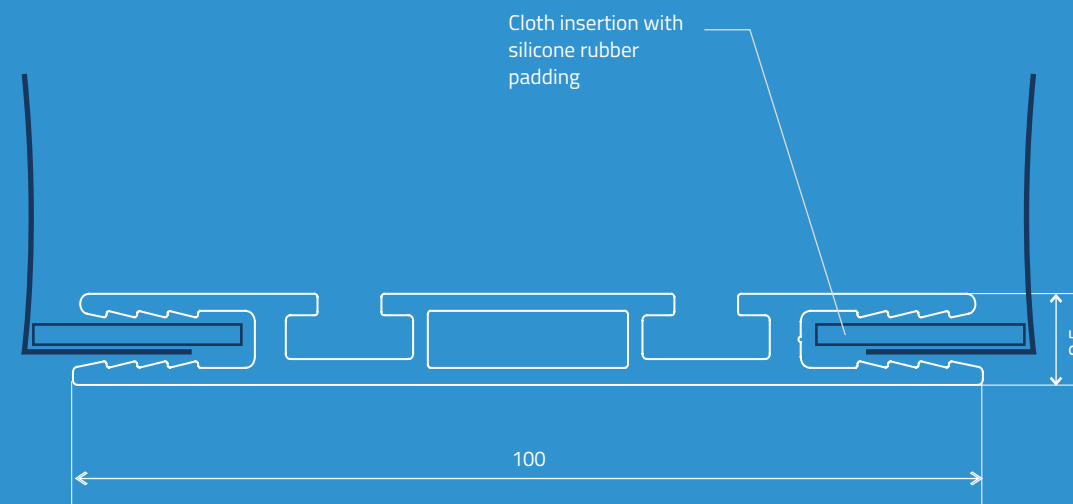
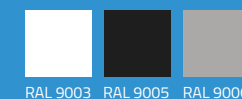





Londra Series



## Londra 120 Double-sided

Extruded aluminium profile for fabric tensioning with rubber. Ideal for small and medium-sized bright double-sided lightboxes, suspended or self-supporting fixing.

Available colours:



RAL 9003 RAL 9005 RAL 9006

Cloth insertion with  
silicone rubber  
padding

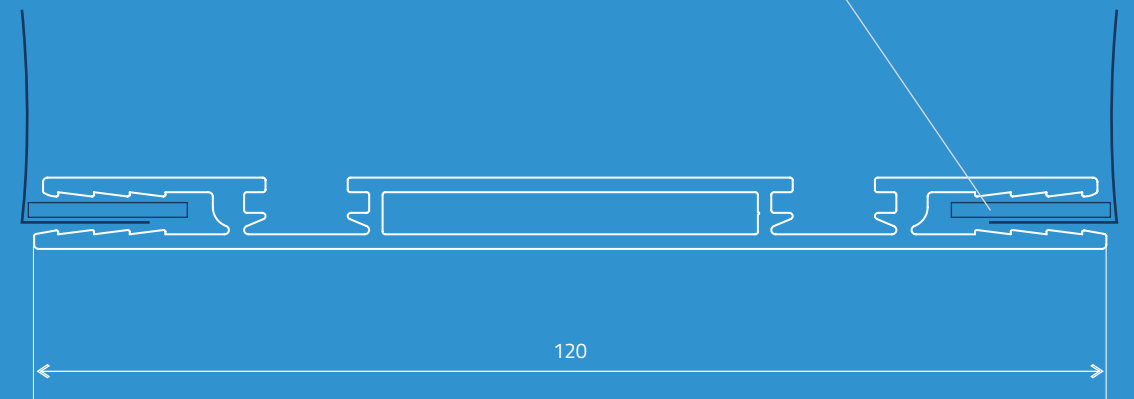



## Londra 140 Double-sided

Extruded aluminium profile for fabric tensioning with rubber. Ideal for small and medium-sized bright double-sided lightboxes, suspended or self-supporting fixing.

Available colours:

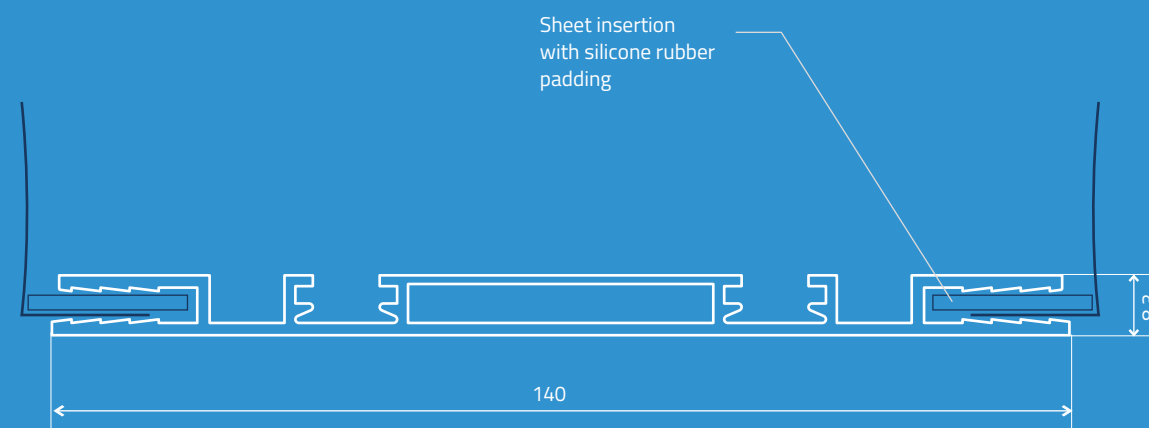





## Roma 80 Single-sided

Extruded anodised aluminium profile for light boxes. Ideal for small single-sided boxes for indoor and outdoor use.

Available colours:

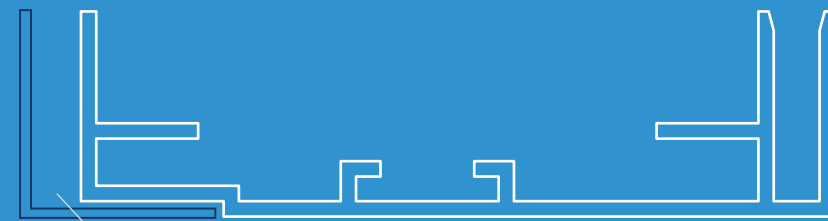
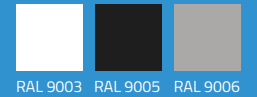

Insertion of Plexiglass plate  
or blind panel

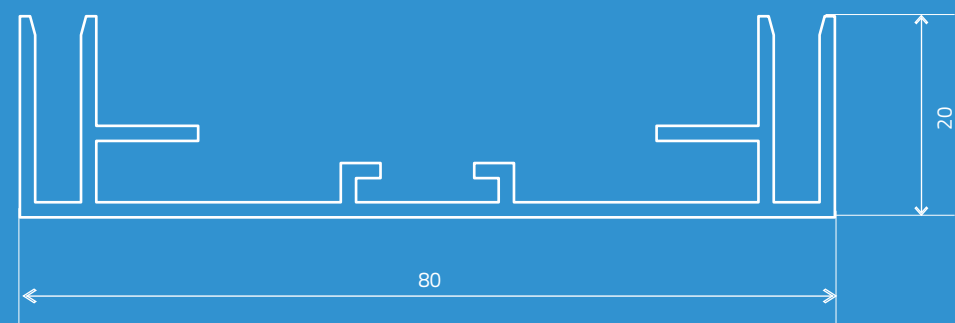



## Roma 110 Single-sided

Extruded anodised aluminium profile for light boxes. Ideal for single-sided and double-sided boxes of medium and large dimensions for indoor and outdoor use.

Available colours:

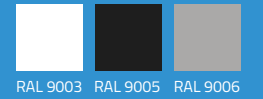

Insertion of Plexiglass plate  
or blind panel

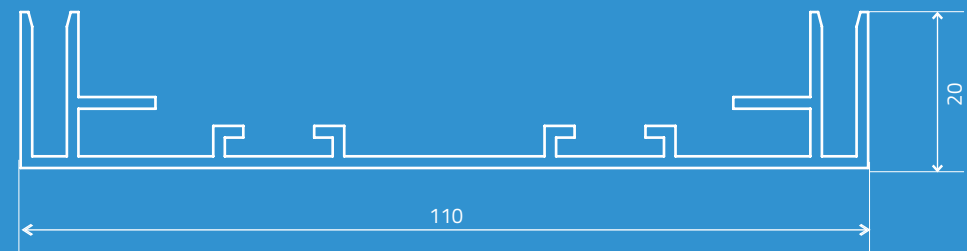





## Roma 140 Double-sided

Extruded anodised aluminium profile for light boxes. Ideal for small and medium-sized single-sided boxes for indoor and outdoor use.

Available colours:



RAL 9003 RAL 9005 RAL 9006



Insertion of Plexiglass plate  
or blind panel





## Washington 140 Single-sided

Extruded aluminium profile for PVC sheet tensioning with special accessories. Ideal for large, single-sided light boxes.

Available colour:



RAL 9006

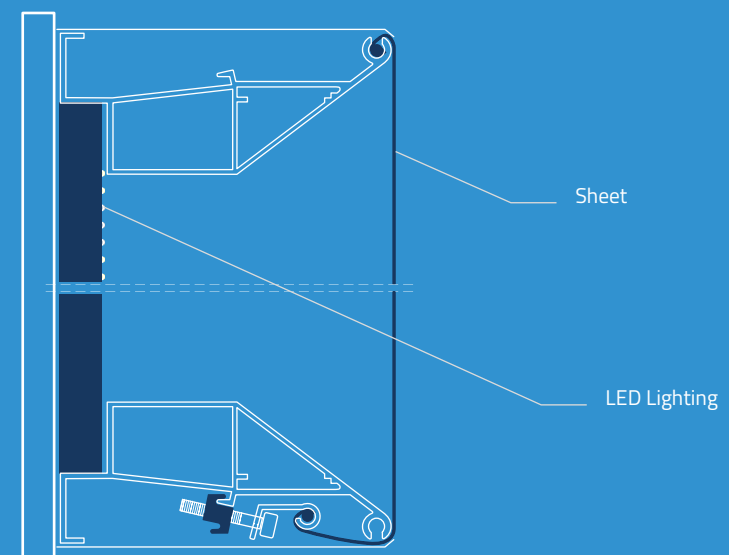
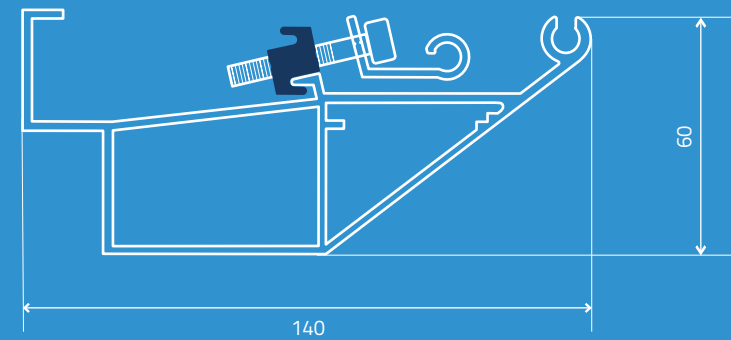



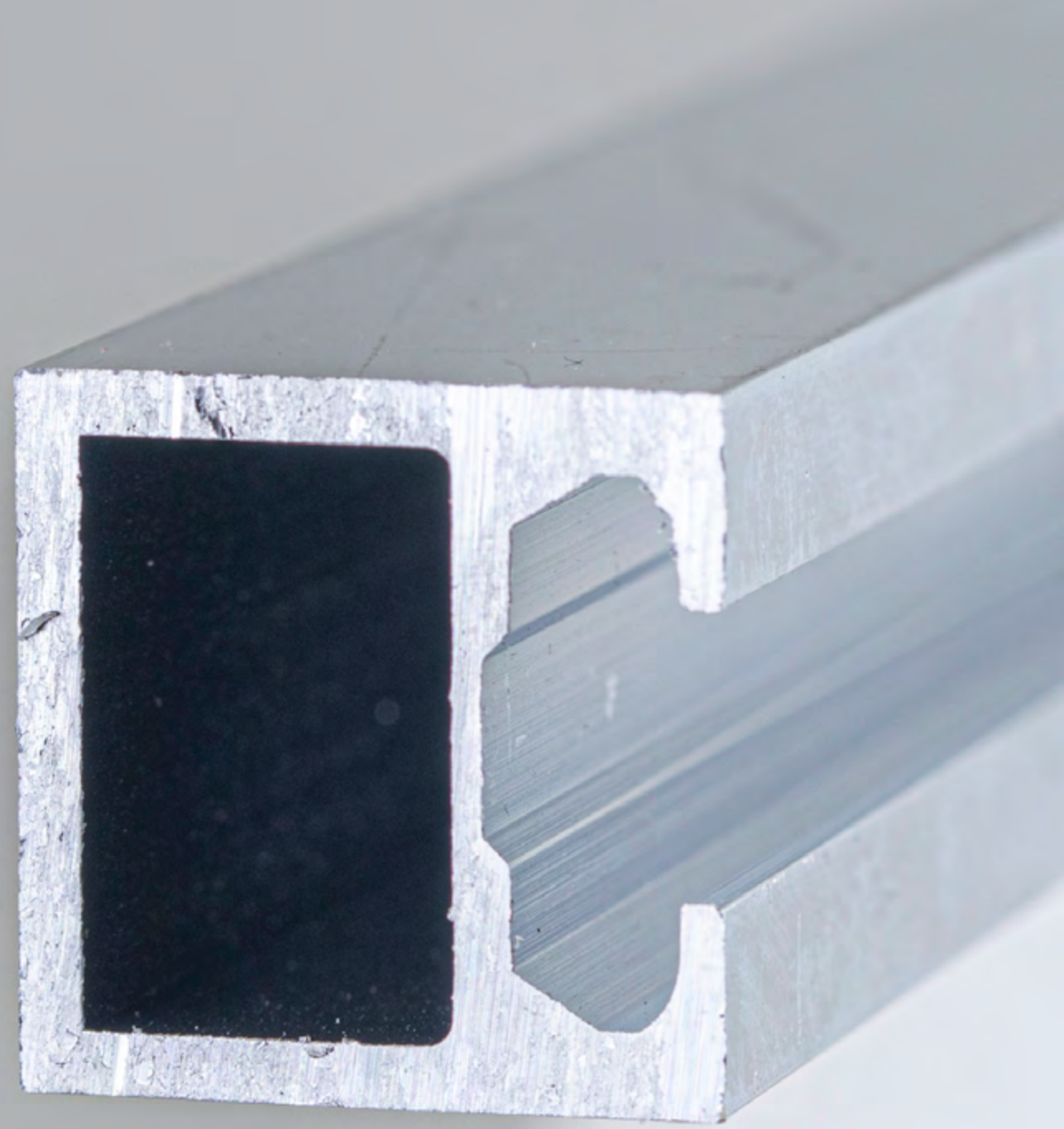

## Tirana Single-sided

Extruded aluminium profile for tensioning with PVC sheet with staples. Ideal for large, single-sided light boxes.

It is used to create structure of any shape.

Available colour:



RAL 9006

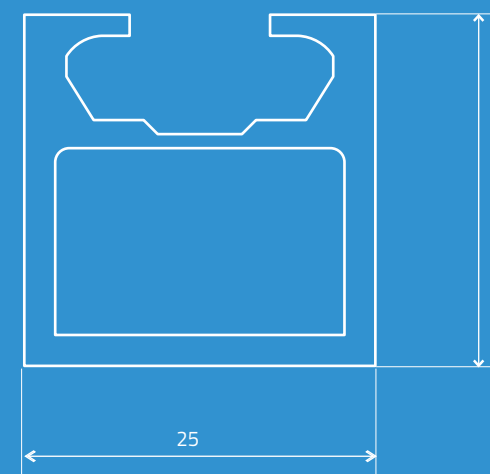
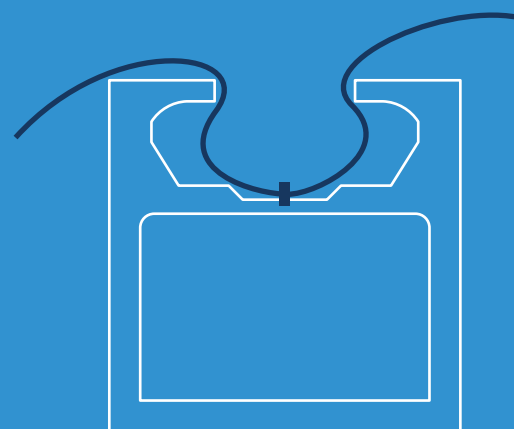

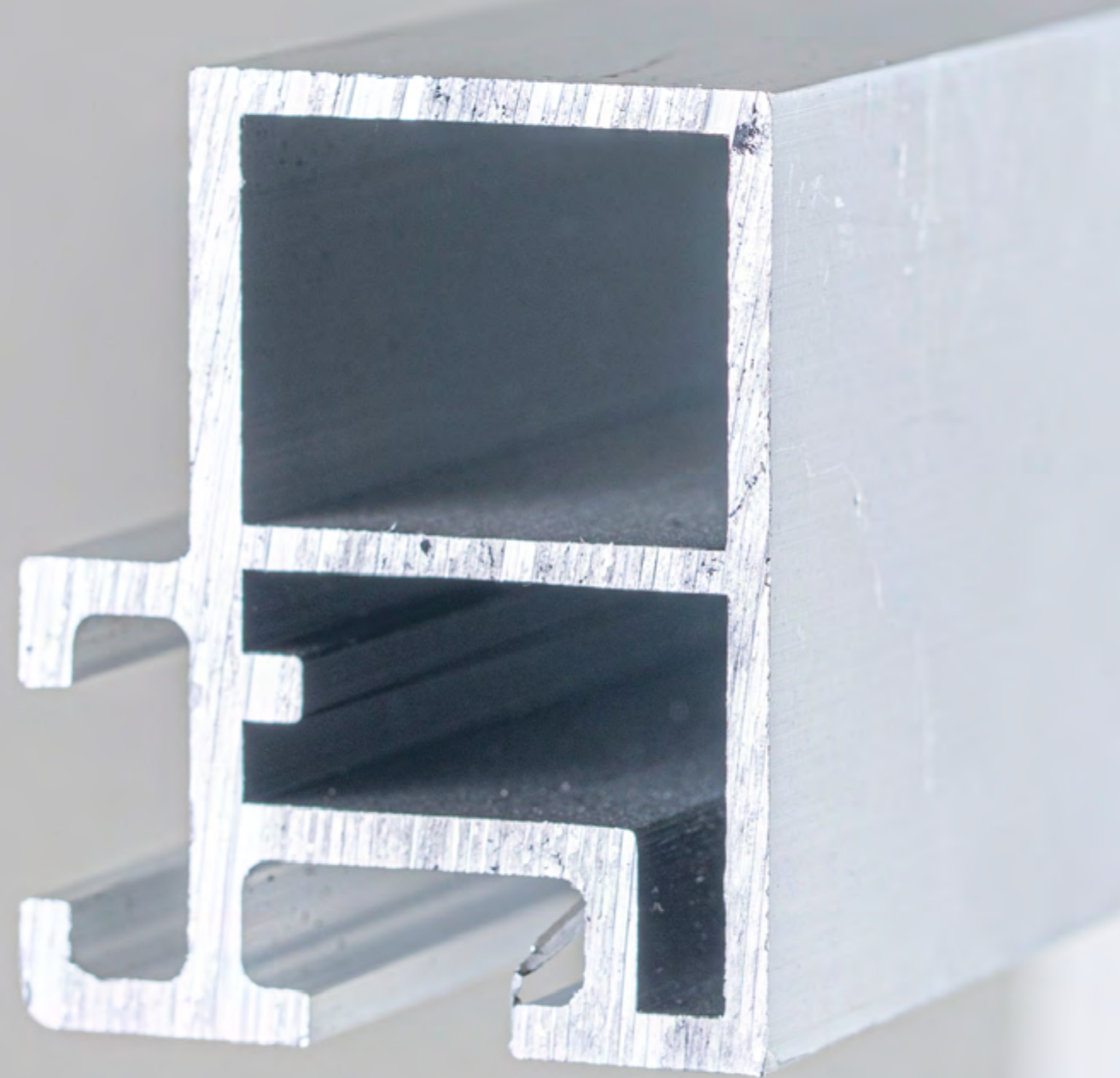

## Atene Single-sided

Extruded aluminium profile for PVC sheet tensioning with dedicated gaskets. Ideal for large, single-sided non-luminous boxes.

Available colour:



RAL 9006

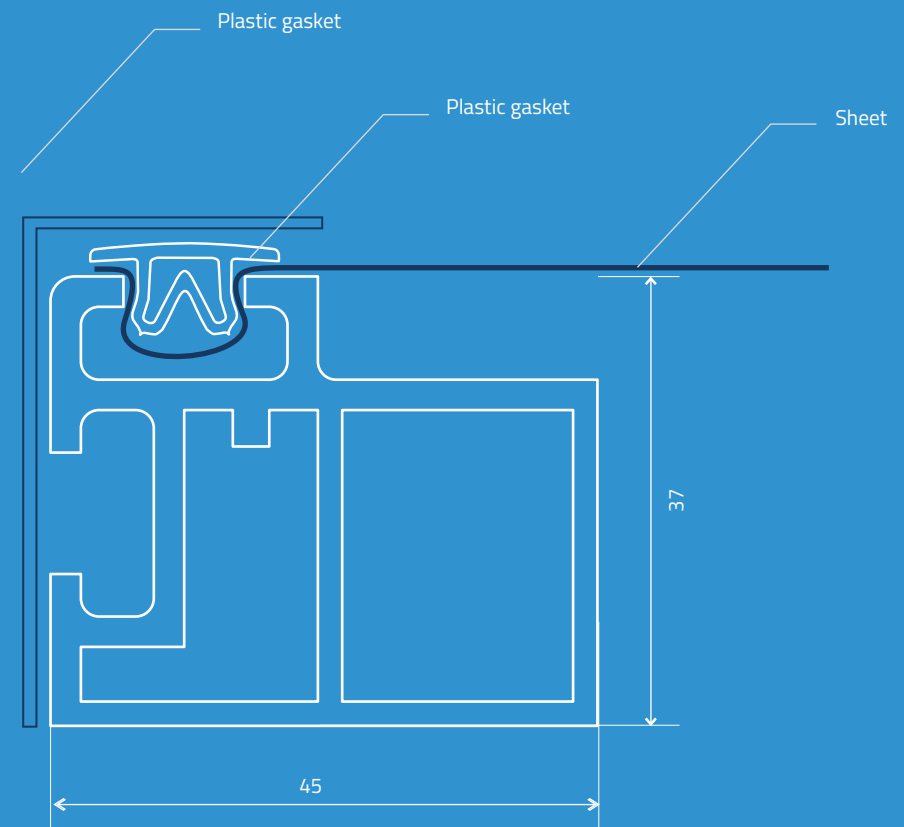



## Accessories



A10  
Plastic gasket



A20  
Canvas fixing clip with  
threaded hole and screw



A30  
Sheet tensioning  
profile



A40  
Linear join plate

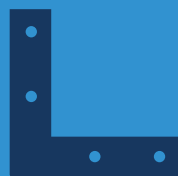

A50  
Join bracket 45°

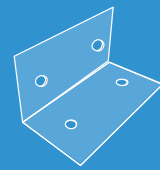

A60  
Profile bracket

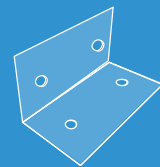

A70  
Profile bracket



A80  
Angular profile  
mm = 20x20

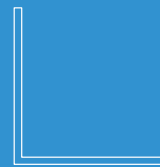

A90  
Angular profile  
mm = 50x50



A 100  
Perimeter edge

### WHOLE ALUMINIUM BARS 6,000 MM

20 x 10 x 2 x 6000  
15 x 15 x 2 x 6000  
20 x 20 x 2 x 6000  
25 x 25 x 2 x 6000  
30 x 30 x 2 x 6000  
35 x 35 x 2 x 6000

40 x 40 x 2 x 6000  
50 x 50 x 2 x 6000  
40 x 10 x 2 x 6000  
40 x 20 x 2 x 6000  
50 x 25 x 2 x 6000  
60 x 60 x 2 x 6000





## INSTALLATION AND SET-UPS

### Change the face of your business

If the sign is one of the many products we deal with, the setting up is its natural stage where the work finds full impact, making the strategy effective and winning.

Changing the face of your business, thanks to a designed, studied and made to measure set-up, will allow you to find a unique voice in an increasingly crowded market which not always guarantees of quality and efficiency.







## Trust the professionals

Our team is made up of highly qualified and experienced specialists, eager to carry out even the most complex projects. The installation process is monitored before, during and after implementation.

## A complete service

We offer a precise installation and maintenance service for advertising systems, road signs, window decorations and vehicles, also arranging any bureaucratic management of permits and authorisations.

## Just one interlocutor

Whether it is internal or external installations, we take care of every single detail, without any intermediary charge including the inspection for verification, the feasibility study and the actual installation

In order for an idea to be fully realised even in the most complex cases, the right means are essential: we have actual "one-stop workshops".

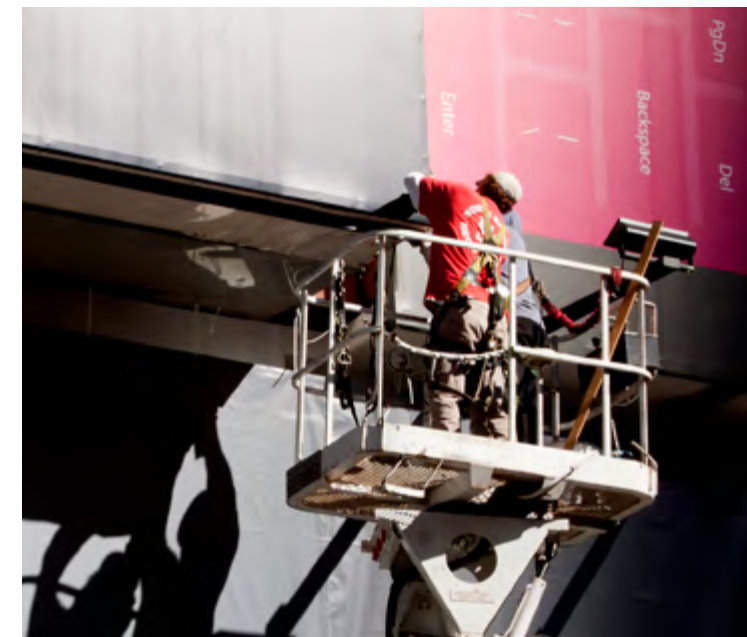



## Set-ups and stands

The experience gained in the design and construction of signs finds its natural extension in the field of interior fittings.

We are able to create tailor-made projects for shops, banks, supermarkets and large spaces, as well as stands for exhibitions and trade fairs.



## Vehicle decoration

The personalisation of vehicles is an excellent communication system as it allows you to splash your corporate image on any type of vehicle, whether it is an individual vehicle or large company fleets.

We deal with the wrapping of cars, vans of all sizes, trucks and buses, offering solutions that always focus on the objectives, with graphics that are customised and studied together with the customer.

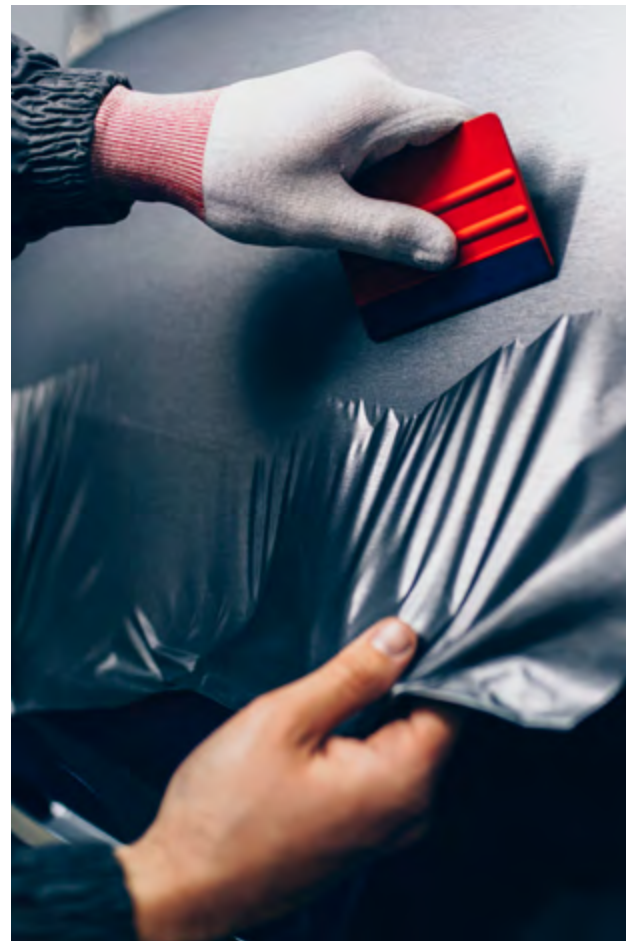



**Marni Group Srl**  
Via Camillo Golgi, 27  
25064 Gussago BS

[info@marnigroup.com](mailto:info@marnigroup.com)  
+ 39 030 312771